



Tigo Energy Intelligence



Tigo Energy Intelligence Inverter Installation and Operation Manual

002-00091-00 | 10/19/2021

1 | Page



Disclaimer

DISCLAIMER OF WARRANTIES AND LIMITATION OF LIABILITY

The information, recommendations, descriptions, and safety disclosures in this document are based on Tigo Energy, Inc.'s ("Tigo") experience and judgment and may not cover all contingencies. If further information is required, a Tigo sales office should be consulted. Sale of the product shown in this document is subject to the terms and conditions outlined in the Tigo warranty or other contractual agreement between Tigo and the purchaser.

THERE ARE NO UNDERSTANDINGS, AGREEMENTS, WARRANTIES, EXPRESSED OR IMPLIED, INCLUDING WARRANTIES OF FITNESS FOR A PARTICULAR PURPOSE OR MERCHANTABILITY, OTHER THAN THOSE SPECIFICALLY SET OUT IN ANY EXISTING CONTRACT BETWEEN THE PARTIES. ANY SUCH CONTRACT STATES THE ENTIRE OBLIGATION OF TIGO. THE CONTENTS OF THIS DOCUMENT SHALL NOT BECOME PART OF, OR MODIFY ANY CONTRACT BETWEEN, THE PARTIES.

In no event will Tigo be responsible to the purchaser or user in contract, in tort (including negligence), strict liability or otherwise for any special, indirect, incidental or consequential damage or loss whatsoever, including but not limited to injury to persons, damage or loss of use of property, equipment or power systems, cost of capital, loss of power, additional expenses in the use of existing power facilities, or claims against the purchaser or user by its customers resulting from the use of the information, recommendations and descriptions contained herein. The information contained in this document is subject to change without notice.



Contents

Disclaimer.....	2
Contents.....	3
Safety Symbols.....	6
Safety Information.....	7
Photovoltaic Rapid Shutdown System Requirements.....	8
EI Residential Solution Overview.....	8
The Energy Intelligence Residential Solution.....	9
Transportation and Storage.....	10
Understanding this Document.....	10
Installation.....	10
EI Inverter Package Contents.....	10
Tools & Items Needed for Installation.....	12
EI Inverter Overview.....	12
EI Inverter Labels.....	13
EI Inverter Weight and Dimensions.....	14
Selecting the Installation Location.....	14
Installation requirements.....	15
Opening the Conduit Holes.....	17
Mounting the Inverter.....	18
Electrical Connections.....	19
Electrical Safety.....	19
Optional GEC/Bonding Connection.....	20
Supported Grid types.....	20
AC Connections.....	21
AC Conduit.....	22
AC Grid Connections.....	22
AC Backup Connections – Battery systems only.....	24
PV Connections.....	25
TS4 Introduction.....	25





Rapid Shutdown, Module-level Monitoring, Optimization.....	25
Rapid Shutdown.....	25
TS4 Installation.....	26
Tigo Access Point (TAP).....	27
TAP Installation	27
DC Connections.....	30
DC Conduit	30
Connecting the PV Strings.....	31
Battery Connections.....	33
Battery Communications Connection	34
Rapid Shutdown Initiator	36
E-Stop Installation.....	37
E-Stop wiring.....	37
Energy Meter	38
Meter Installation	39
Wiring the Meter	39
Meter Status Indication	42
Antenna Connections.....	43
Commissioning.....	44
Pre-power Check.....	44
Torque Table	45
Powering on the EI Solution.....	45
LED Status	46
Powering Off the EI Solution.....	47
Reset Button	48
After Installation	48
Cleaning and Care	48
Maintenance	49
Troubleshooting.....	49
Your Tigo Customer Support contact.....	49
Decommissioning.....	51
Removing the inverter	51







Packing the inverter	51
Storing the inverter.....	51
Disposing of the inverter.....	51
Warranty	51
Specifications	52
Efficiency Curves	53
Ambient Temperature	55
Inverter data tolerance	55
Annex	56
Rule 21 Parameter Settings	56
R21 parameter settings.....	56
Normal and soft start ramp rates	57
Fixed power factor	58
Dynamic Volt/VAR.....	58
Frequency-Watt (FW)	59
Voltage-Watt (VW).....	59

Safety Symbols

The following safety symbols are used in this Installation and Operations manual. Please review these symbols and their meanings before installing or operating the system.

Symbol	Explanation
	WARNING indicates a hazardous situation which, if not avoided, could result in serious injury or loss of life . AVERTISSEMENT indique une situation dangereuse qui, si elle n'est pas évitée, pourrait entraîner la mort ou des blessures graves.
	CAUTION indicates a hazardous situation which, if not avoided, could result in minor or moderate injury and damage of the product . ATTENTION indique une situation dangereuse qui, si elle n'est pas évitée, pourrait entraîner des blessures mineures ou modérées.
	NOTE is used to address additional information about the section's subject matter. AVIS est utilisé pour traiter des pratiques non liées aux blessures corporelles.

On the inverter

Symbol	Explanation
	Risk of electrical shock Risque d'électrocution
	Risk of burn injuries Risque de brûlures
	Wait for 5 minutes before engaging in the indicated action Attendez 5 minutes avant de vous engager dans l'action indiquée
	Earth Ground Terre au sol
	Observe the operating instructions Respectez les instructions de service



Safety Information

Save these instructions.

	Warning! Read all instructions in this manual to reduce risk of injury, damage, and loss of life.
	The equipment detailed in this document are to be installed and maintained by qualified personnel only.
	The DC Disconnect Switch must be turned to the OFF position before opening the cover of the inverter wirebox. Wait 5 minutes before opening the cover. Stored energy within capacitors poses risk of electric shock.
	This product could expose the user to chemicals known to the State of California to cause cancer. For more information refer to www.P65Warnings.ca.gov .

	Caution! This product must operate within the technical specifications of the datasheet.
---	--

	Note Before operation, ensure the inverter is properly grounded. Comply with local requirements for grounding PV modules and inverters. This inverter must be connected to a permanent grounded wiring system. An equipment grounding conductor must be used in the circuit conductors and properly terminated at the inverter's equipment grounding terminals.
	The inverter is NEMA 4X rated. Unused conduit openings must be properly sealed and all connecting conduit requires the use of appropriate fittings for the application.
	This is a transformerless inverter; it does not contain an isolation transformer and must be installed with an ungrounded PV array in accordance with NEC 690.35 and 690.43.
	Use only copper conductors, solid or stranded. Never use fine stranded conductors. All conductors must have a minimum temperature rating of 75°C.

Photovoltaic Rapid Shutdown System Requirements

	<p>Caution!</p> <p>The Tigo EI Inverter is Photovoltaic Rapid Shutdown System (PVRSS) Certified with Tigo’s TS4 products to ensure rapid shutdown compliance to 2017 and 2020 NEC 690.12. Additional, non-Tigo equipment installed in this system may adversely affect the operation of this PVRSS. It is the responsibility of the installer to ensure the installed system complies with rapid shutdown functional requirements.</p>
---	---

The Tigo EI Inverter and TS4 module-level power electronics (MLPE) have been designed, evaluated, and certified as a Photovoltaic Rapid Shutdown System (PVRSS) complying with the 2017 and 2020 editions of the National Electric Code (NEC). All conductors both inside and outside the array boundary will contain reduced voltage, below 30V_{DC} within 30 seconds.

Where rapid shutdown is required, all PV modules connected to an EI Inverter must be connected to a TS4-A-O or TS4-A-F to provide rapid shutdown functionality. Buildings with PV systems requiring rapid shutdown shall have permanent labels located at the service equipment to which the system is connected, or an approved readily available location. The label on the right is included in the inverter packaging.

The Rapid Shutdown Initiation Device is required to be labeled per NEC 690.56(C)(2). This label shall be on or within 3 feet of the initiation device and contain the words “RAPID SHUTDOWN SWITCH FOR SOLAR PV SYSTEM”. The label shall be reflective, written in all capitalized letters and have a minimum height of 9.5mm (3/8 in) in white on red background.

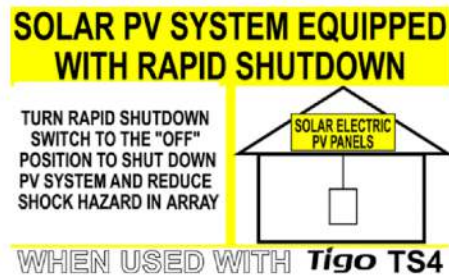

Figure 1 Rapid Shutdown Label

EI Residential Solution Overview

The Energy Intelligence Inverter is Tigo’s hub to energy independence. The EI Inverter is a single-phase energy converter which manages the PV energy produced, converts the energy to AC for immediate use in the home or backfed to the utility grid. When paired with the Tigo EI Battery, the inverter manages the battery charging and discharging based on the user’s preferences and/or local requirements. The EI Inverter operates with Tigo’s TS4 MLPE products to provide PV module-level optimization, safety, and the most granular module-level monitoring in the industry. When used with Tigo’s EI Monitoring platform the entire energy system is monitored and managed through automatic alerts in case of any issues or abnormalities.

The Energy Intelligence Residential Solution

The EI Residential Solution includes the following components:

1. **EI Inverter** – The TSI-7.6K-US and TSI-11.4K-US inverters may be installed as grid-tied only or as an energy storage system when paired with the EI Battery. The inverter converts the PV array’s DC energy to AC for use in the building and when paired with an EI Battery, acts as the battery management unit.
2. **TS4** – Tigo’s MLPE, the TS4-A-F provides module-level rapid shutdown. The TS4-A-O provides module-level monitoring, rapid shutdown, and best-in-class module-level optimization with Tigo’s patented Predictive IV.
3. **EI Battery** (optional) – The LFP battery is designed for use specifically with the EI Inverter. Up to four battery enclosures may be installed with the EI Inverters.
4. **EI ATS** (optional / required when batteries are used) – The EI ATS is an automatic transfer switch which switches the home loads from grid + Solar/battery usage to solar/battery usage only when the grid goes down. This is a required component to any energy storage system when connected to the utility grid as it prevents the potential for dangerous backfeed on the utility’s conductors.
5. **Energy Meter** – (optional / required when batteries are used) – The energy meter monitors the import and export of energy into the home’s electrical system. This allows the inverter to determine when and how much energy is required from the battery to serve connected loads.
6. **EI Platform** – Accessible through the web or mobile app, the EI Platform provides visibility into system and module performance. The EI mobile app is also used for commissioning the EI Residential Solution.

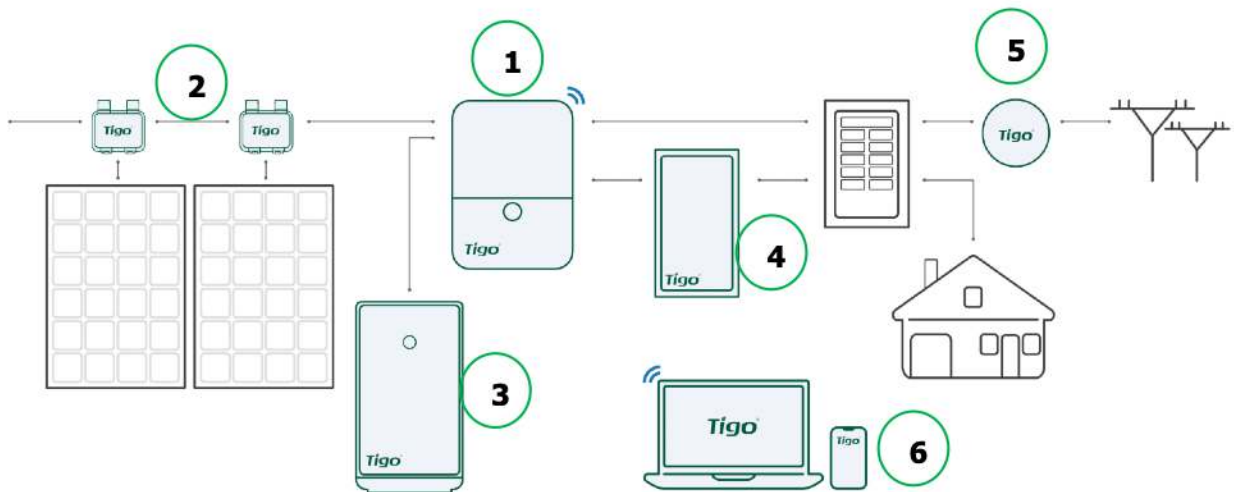

Figure 2 EI System Diagram



Transportation and Storage

When possible, transport the inverter in its original packaging, facing up and do not expose to inclement weather or unnecessary shocks and vibrations. If the original packaging cannot be used, a box of similar size, without damage, and can accommodate the weight of the inverter may be used. Take precaution to ensure the packaging is fully closed and reasonably weather tight.

To store the inverter, select a dry environment with ambient temperatures of -22°F to 149°F (-30°C – 65°C).

**Note**

Never store power electronics for long periods of time as internal components can degrade over long periods with no electrical charge.

Understanding this Document

This manual includes installation references to all five separate components of the complete Energy Intelligence Residential Solution: MLPE, inverter, battery, ATS and energy meter. Not all components are necessary for the proper operation of the EI Inverter and sections not pertaining to an individual installation may be skipped.

Installation of the equipment can take place concurrently, although the EI Inverter is the hub of all equipment in this system. Where a workstream can split off from the main efforts of inverter installation a QR code will be provided directing to the appropriate product's documentation.

Installation

When receiving delivery of the inverter, examine the packaging for damage. If the packaging appears to have damage through the box and into the contents, refuse delivery and notify the vendor immediately. If damage appears external only, open the box and inspect for any product damage and/or missing parts.

EI Inverter Package Contents

Open the package and inspect the contents. The following components should be included. If anything is missing, please contact the vendor immediately.

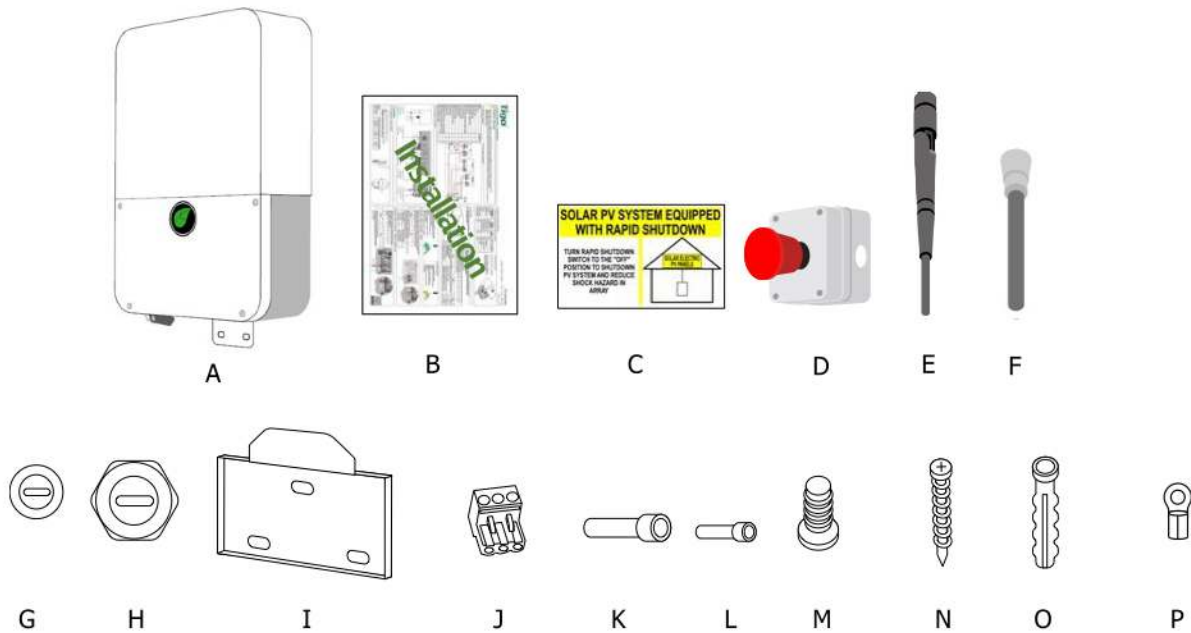

Figure 3 Package Contents

Table 1 Package contents

Item	Description	Quantity
A	TSI inverter	1
B	Quick Start Guide	1
C	Rapid Shutdown Label	1
D	Rapid Shutdown Initiation Switch	1
E	WiFi Antenna	1
F	Cellular Antenna (only for cellular enabled models)	1
G	3/4" Conduit hole caps	2
H	1" Conduit hole plugs	4
I	Mounting Bracket	1
J	RS485 3-pin connector (meter)	1
K	AC wire ferrules	5
L	DC wire ferrules	16
M	Safety-lock screw	2
N	Self-tapping screw (Inverter & RSD mounting)	7
O	Plastic wall anchor (Inverter & RSD mounting)	7
P	Type-O grounding connector	1

Tools & Items Needed for Installation

Table 2 Required Tools

Item	Needed for:
3/16" (5mm) screwdriver	Removing/replacing covers
1/8" flat screwdriver	Making wire terminations
Mallet/Hammer	Making wall anchors flush
Tape measurer	Determining mounting locations and clearance requirements
Pencil	Marking drill holes
Level	Mounting the equipment
Drill & drill bit	Drilling pilot holes for mounting – bit size will depend on the mounting surface material and anchor sizes required.
3/4" and 1" hole saws	Removing the drill guide from inverter wirebox

EI Inverter Overview

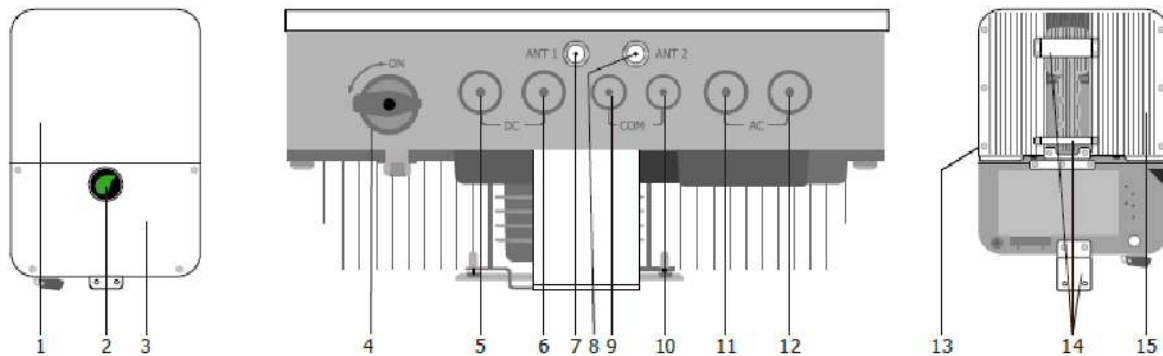

Figure 4 Inverter Overview

- | | | |
|-------------------------|--------------------------|------------------------------|
| 1) Front panel | 6) Battery input | 11) Backup output |
| 2) LED indicators | 7) Wifi antenna port | 12) AC grid output |
| 3) Wirebox cover | 8) Cellular antenna port | 13) External grounding point |
| 4) DC disconnect switch | 9) TAP/Meter/RSD input | 14) Mounting bracket |
| 5) PV input | 10) Battery com input | 15) Heat sink |

EI Inverter Labels

Inverter labels provide the technical specifications of the product as well as important safety information. Additional information is available on these and other labels which will help with the commissioning and installation of the inverter.

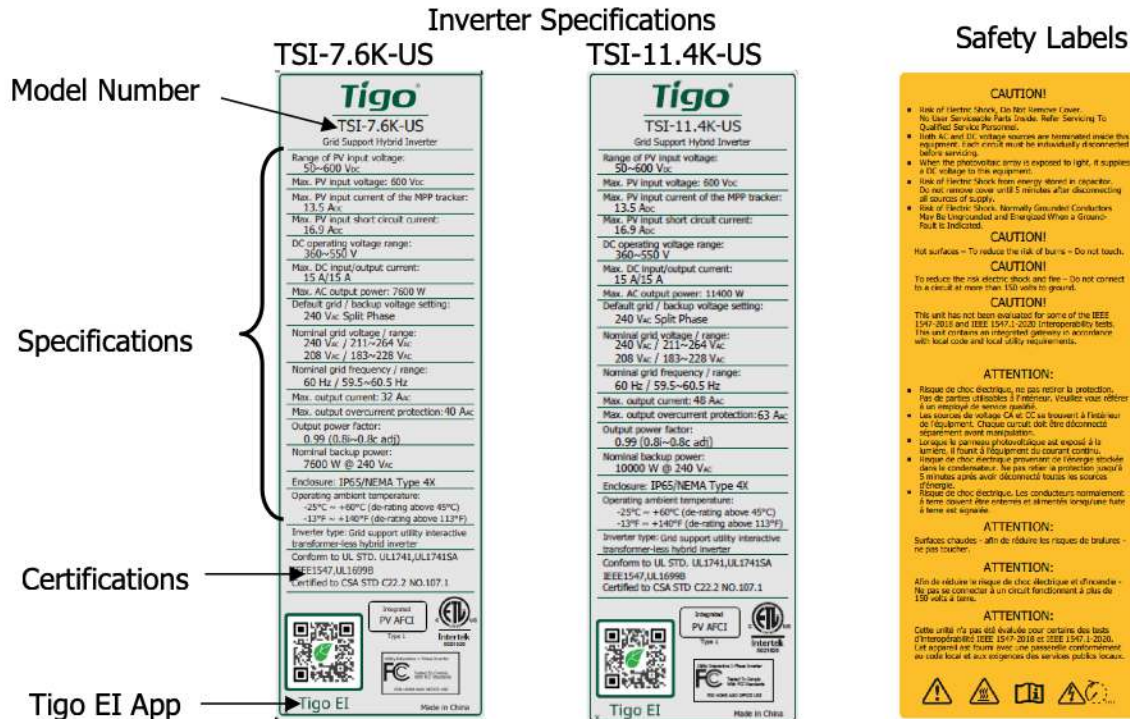

Figure 5 Inverter Exterior Labels

The EI Inverter includes a label with the inverter’s MAC ID and QR code. This is used to identify the specific inverter to communicate with during the commissioning process in the event multiple inverters or devices are displayed in the EI app. This QR code label can be found on the left side of the inverter enclosure, below the specification label.



Figure 6 Inverter MAC ID

The inside of the inverter’s wirebox contains two labels. The first label on the left side of the wirebox specifies the DC input terminals for PV and battery connections. The label on the right side specifies the AC output terminals for grid and ATS (backup) connections.

1	2	3	4	1	2	3	4	+	-
PV+				PV-				BAT	

Figure 7 DC Connections

L2	L1	L1	N	L2
BACKUP		GRID		

Figure 8 AC Connections

EI Inverter Weight and Dimensions

Table 3 EI Inverter weight & dimensions

Model	Dimensions (W x D x H)	Weight
TSI-7.6K-US	15.75 x 7 x 22 in (400 x 570 x 178mm)	32.3lbs (14.7kg)
TSI-11.4K-US	15.75 x 7.4 x 25 in (400 x 638 x 187mm)	45.2lbs (20.5kg)

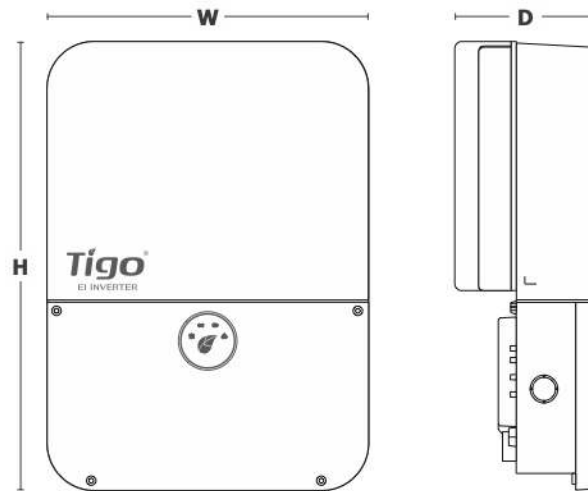

Figure 9 TSI-7.6K-US/TSI-11.4K-US dimensions

Selecting the Installation Location

Selecting the installation location of the inverter requires some special considerations.

- If the EI Inverter is to be used as a grid-tied inverter only and no battery backup is expected to be included, it is recommended to install the inverter close to the point of interconnection (Main service panel). This is to reduce the potential for AC voltage drop.
- If the EI battery is to be installed now or at some point in the future, consider the conduit path and determine an installation location that would ensure an easy and clean installation.

The inverter's DC connections are on the left side of the inverter and AC grid/backup connections are on the right. The EI battery to inverter connections are on the left of the EI battery enclosure.



Note

When installing the energy meter (required for battery installs) note that the CT conductor length is 80 inches. THESE MUST NOT BE CUT OR SPLICED. The meter should be installed in or next to the main service panel.

Installation requirements

The inverter installation must comply with the following requirements.

- The inverter must be mounted at least 36 inches (91.5cm) above the ground. The installation location must be suitable for the inverter's weight and dimensions over the course of its life.
- Select a wall or solid vertical surface that can support the inverter.
- Select an installation location in which the LED display will be easily viewed.
- Select a well-ventilated location sheltered from direct sunlight and rain. Do not install in cabinets. Good ventilation ensures the heat will adequately escape. The ambient temperature should be below 40°C for optimal operation.
- Do not install the inverter on structures constructed of highly flammable materials.
- The humidity at the installation location must be 0-100% without condensation.
- The installation location shall always be accessible.
- Mount the inverter vertically or tilted back no more than 15°. Never install horizontal, tilting forward, sideways or facing upside down.

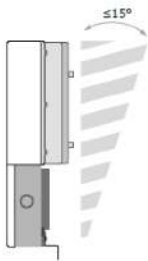

Figure 10 Approved installation

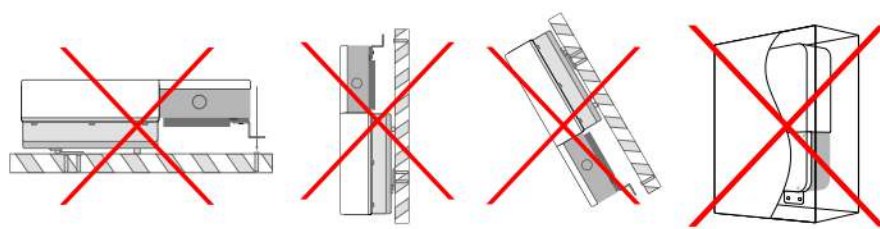

Figure 11 Non-approved installations

- Ensure the inverter is out of reach of children.
- Do not cover or place items on the inverter.
- Do not install in locations with strong electromechanical interference, and away from any antennas.

The minimum clearances shown below must be observed.

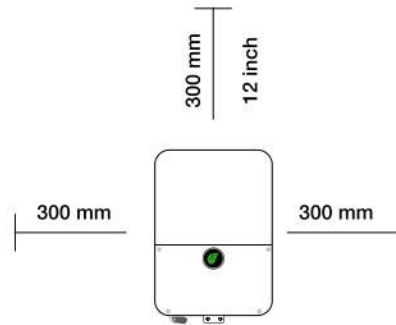

Figure 12 Single inverter clearance requirements

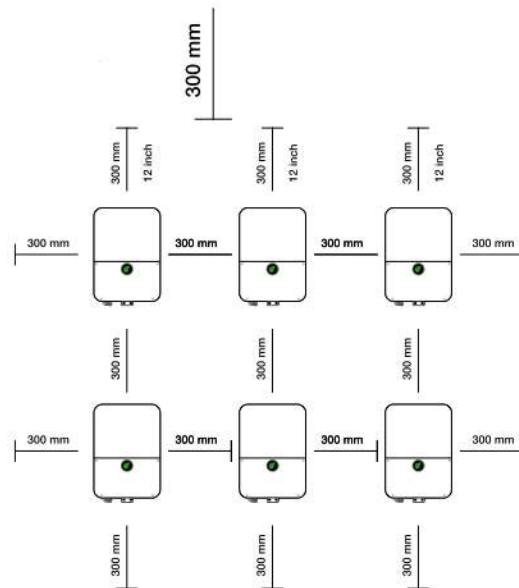

Figure 13 Multi-inverter clearance requirements

- Sufficient clearance between individual inverters is required to ensure the warm air dissipating from one inverter does not increase the operating temperature of adjacent inverters. If necessary, increase the clearance space between inverters to ensure sufficient cooling.
- Do not install inverter in direct sun, rain, or snow.



Figure 14 Inverter exposure requirements

Opening the Conduit Holes

Tools needed: 3/4" & 1" hole saw, drill, 3/16" hex head screwdriver

	<p>Note: This step is recommended prior to mounting the inverter to avoid contact with live voltage.</p>
	<p>Caution! Do not come in to contact with any internal components of the wirebox when drilling out the conduit holes.</p>

Determine which conduit drill guides need to be removed. The openings will depend on the equipment being installed in this system. In case drill guides are opened but left unused, hole plugs (**G, H**) are provided to close these openings and ensure a water-tight seal.

Table 4 Conduit Drill Guide

References in Guides	Label on Inverter	# on diagram	Drill / if installing
PV input	DC (left side)	5	Yes / PV
Battery input	DC (right side)	6	Yes / battery
Comm	COM (left side)	9	Yes / TAP, meter, RSD switch
Comm	COM (right side)	10	Yes / battery
Backup output	AC	11	Yes / ATS
AC grid output	AC	12	Yes

- Using the 3/16" hex head screwdriver, loosen the four screws on the front cover of the wirebox (**3**) and remove cover.
- The conduit openings can be opened for trade size 3/4" (COM) or 1" (AC & DC) conduit. CAREFULLY open the required conduit openings using the drill guide and hole saw drill.

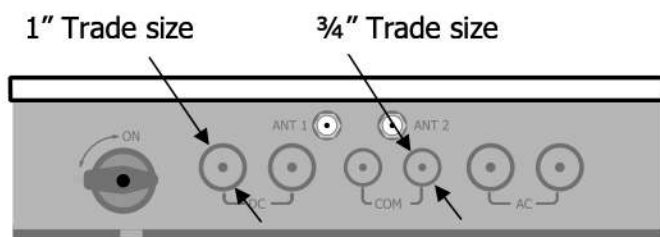

Figure 15 Conduit size reference

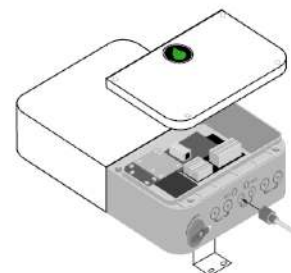



Figure 16 Preparation for mounting

Mounting the Inverter

Tools needed: Electric drill, hammer/mallet, tape measurer, level, pencil, socket wrench

Accessory parts needed: Wall anchors (O), self-tapping screws (N), mounting bracket (I)

	Warning! Before drilling into the wall, inspect for existing electrical or plumbing installations to avoid electric shock or other injury.
	Note The instructions below are for mounting the inverter to drywall. If another mounting surface is used, use appropriate hardware to securely mount the inverter.

1) Mounting Bracket (I):

- a. Place the inverter bracket against the wall, using a level to ensure it is horizontal, and mark the mounting holes with a pencil.
- b. Using a 5mm drill bit, drill the three marked locations from the previous step.
- c. Insert wall anchors (O) in holes and gently tap with mallet/hammer to bring flush with the wall.
- d. Place mounting bracket on wall and secure with the three self-tapping screws (N) included in the accessory bag.

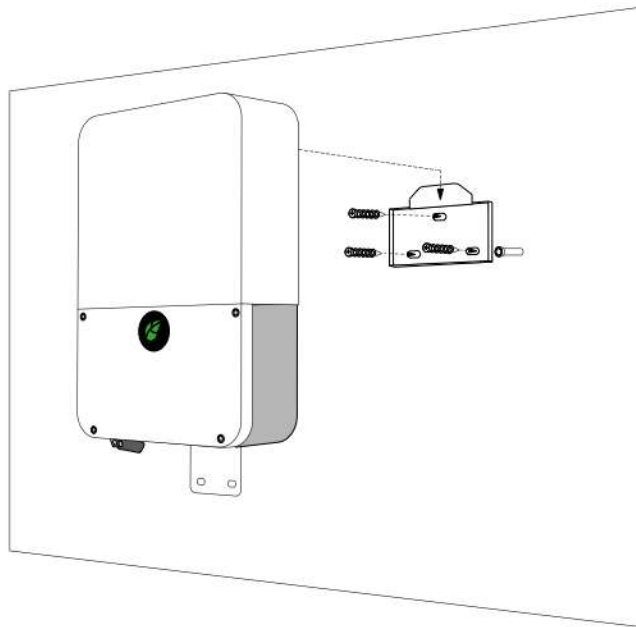

Figure 17 Upper bracket mounting

- 2) Lower inverter bracket:
- The location of the wirebox mounting holes depends on the model of inverter.
 - Place inverter on wall bracket and mark the location of the lower mounting holes.
 - Remove inverter and drill into the wall. Insert wall anchors (O) and gently tap with mallet/hammer to bring flush with the wall.
 - Replace inverter on the upper mounting bracket. Check that the wall anchors line up with the wirebox mounting holes and secure with two self-tapping screws (N).

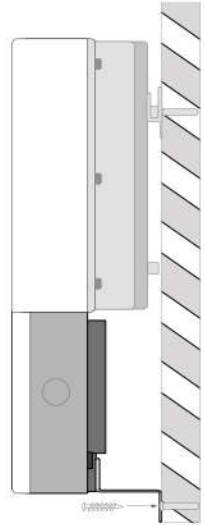







Figure 18 Lower bracket mounting

Electrical Connections

	<p>Note: All electrical installations must be completed in accordance with all local electrical codes and the National Electric Code, NFPA 70 (NEC). For installation in Canada the installations must be completed in accordance with applicable Canadian standards. Before connecting the inverter to the power distribution grid, contact your local electric utility company. These connections may only be made by qualified personnel.</p>
---	---

Electrical Safety

	<p>WARNING! Danger to life from electric shock due to high voltages. High voltages are present in the DC conductors and inverter components during operation. Fatal electric shocks can occur. Before connecting, make sure the AC and DC disconnects are turned off and measure the voltages to ensure power is off before connecting.</p> <p>The DC conductors of this PV system are normally ungrounded but will become intermittently grounded without indication when the inverter measures the PV array isolation. Due to the transformerless design, the DC positive and DC negative poles are not permitted to be grounded.</p> <p>Do not disconnect the DC conductors under load!</p>
	<p>CAUTION! Risk of burns due to hot surfaces. The surface of the inverter can become very hot. During operation do not touch any portion other than the wirebox compartment. Mount the inverter such that it cannot be inadvertently touched.</p>
	<p>WARNING! Always connect the inverter to ground to protect property and personal safety.</p> <p>The inverter must only be operated with a PV generator (array). Do not connect another source of energy to the inverter PV inputs.</p>

	Both AC and DC voltage sources are present inside this inverter. Disconnect these circuits before servicing.
	This inverter is designed to feed power into the utility grid. Do not connect the inverter output terminals to an AC generator. Connecting to external devices could result in serious damage to the equipment.
	When a PV module is exposed to light it generates a DC voltage. When connected to this inverter the PV module will charge the DC capacitors inside the inverter.
	Energy stored in the inverter's capacitors presents a risk of electric shock. Even after the inverter is disconnected from the grid and PV modules, high voltages may still exist inside inverter. Wait at least 5 minutes after disconnecting from all power sources before removing the wirebox cover.
	Before any electrical connections can be made, the inverter must be permanently mounted.
	Before power conductors are connected, both AC and DC ground conductors must be connected first.
	<p>CAUTION!</p> <p>Danger of damage to electronic components due to electrostatic discharge. Take appropriate ESD precautions when replacing and installing the inverter.</p>

Optional GEC/Bonding Connection

If required by an AHJ, a dedicated grounding/bonding point is located on the left exterior side of the inverter. See Item (13) in the EI Inverter Overview section. This connection point may be used for a grounding electrode conductor or equipment bonding if using a metal mounting surface. This ground/bond is not required for operation of the inverter.

Use a crimping tool to crimp the O-type terminal (P) provided in the accessory bag to the bare copper ground/bonding conductor. Attach the O-type terminal to the ground hole using the safety-screw (M) provided in the accessory bag.

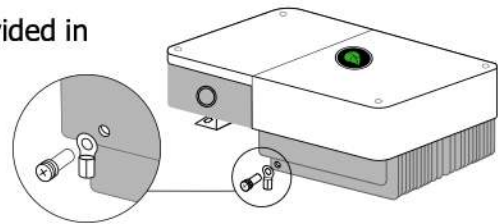

Figure 19 GEC/Bonding Connection

Supported Grid types

The Tigo EI Inverters are grid-tied to the public utility grid. The inverters can operate on 208V_{AC} or 240V_{AC} at 60Hz. During commissioning the grid voltage on which the inverter will operate is chosen through the Energy Intelligence App. The following figures illustrate the types of grid connections supported by the EI Inverters.

	<p>Note:</p> <p>A ground connection is required for the operation of this inverter.</p>
---	--

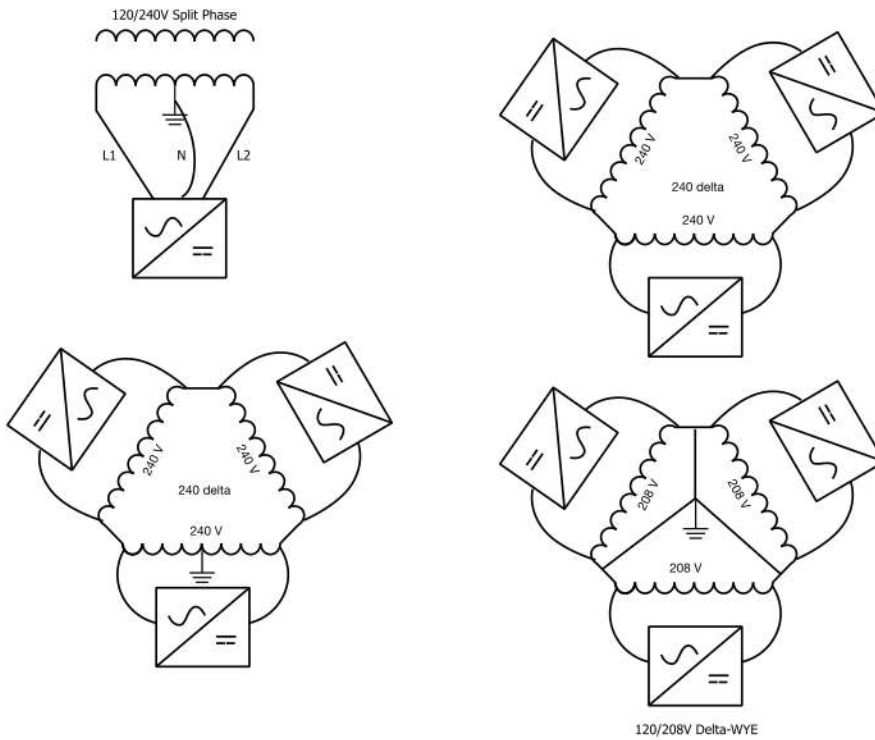

Figure 20 Grid configurations

AC Connections

When using the EI Inverter as a grid-tied-only inverter (no storage), only the L1, L2, and N terminals for the AC “GRID” connections need to be made. In this case, skip “Backup connections” section.

L2	L1	L1	N	L2
BACKUP		GRID		

Figure 21 AC Label

When using the EI Inverter with battery storage, L1 and L2 terminals for the Backup connections will also be needed.

Table 5 AC conductor schedule

Use	Type	Size
Equipment grounding conductors (EGC)	Yellow-green or solid bare copper	10 – 8AWG
AC output conductors (GRID)	Red/Black/White jacket, stranded or solid copper	8 – 4AWG
AC Backup conductors (BACKUP)	Red/Black jacket, stranded or solid copper	8 – 4AWG

	<p>Note: Use only solid or stranded wire for all electrical connections with a minimum temperature rating of 75°C. Never use fine stranded conductors.</p>
--	---

AC Conduit

Supplies needed: 1" conduit and associated fittings.

The right AC conduit opening (**12**) is reserved for the inverter's AC output conductors for connection to the grid. This conduit hole should have been opened prior to mounting the inverter. If not, make sure the inverter is securely mounted and the wirebox cover has been removed before drilling open the conduit drill guide. Use caution to not come in contact with any internal components.

Route the conduit between the inverter and the AC main distribution panel. Use appropriate conduit fittings to ensure a water-tight seal. Bond any metallic conduit, as required.

The left AC conduit opening (**11**) is reserved for the AC Backup conductors which connect to the EI ATS in battery installations. If installing the EI Battery and ATS, route the conduit from the left conduit opening to the ATS. Use appropriate conduit fittings to ensure a water-tight seal. Bond any metallic conduit, as required.

Conductor preparation

Tools required: wire cutter, wire stripper, crimping tool, conductor labels/markings method

Supplies needed: AC conductors, wire ferrules (K)

The power conductors are terminated in the EI Inverter via pressure terminals. These terminals clamp on to the exposed end of the conductor. To ensure a reliable connection always use wire ferrules (**K**) on the end of these conductors.

- 1) Run the AC conductors and EGCs through the appropriate AC conduit. Ensure the conductors have even bends and sufficient strain relief.
- 2) Strip 0.7in (18mm) of insulation from the end of the L1, L2 and N conductors for the AC Grid Output. If installing an EI Battery, strip 0.7in (18mm) of insulation from the end of the L1 and L2 conductors for the AC Backup.
- 3) Use the crimping tool to connect the wire ferrules (**K**) to the conductor ends that will be terminated in the EI Inverter.
- 4) Clearly label all conductors.

AC Grid Connections

Tools required: 1/8" flat screwdriver, #2 philips screwdriver, cable ties, multimeter



CAUTION – Before making the AC connections use a multimeter to measure the grid voltage. Confirm it is within the operating specifications of the inverter. Always connect the EGC of the circuit before the power conductors.

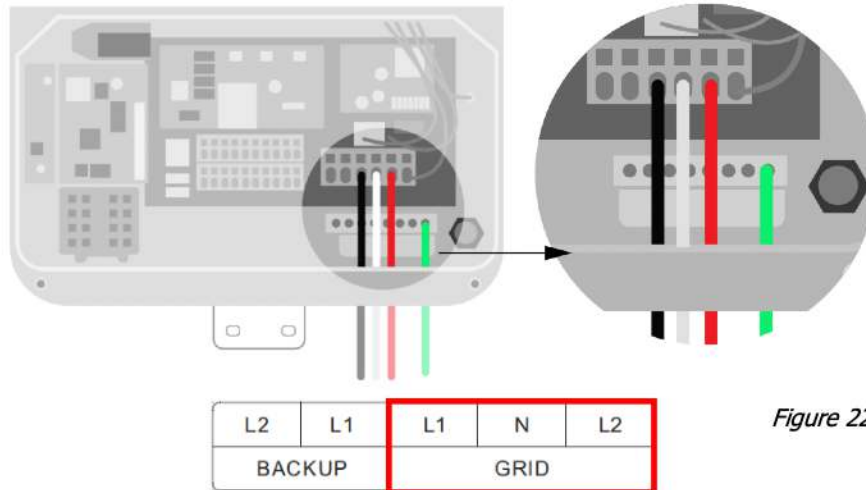

Figure 22 AC Grid connections

- 1) Insert the EGC to the Grounding busbar. Using the #2 philips screwdriver, torque the set screw to 1Nm.
- 2) Insert the 1/8" flat blade screwdriver into the square hole above the L1 wire terminal, pressing to open the clamp.
- 3) Insert the L1 conductor into the appropriate wire terminal according to the labels and remove screwdriver to clamp the conductor.
- 4) Gently tug the conductor to ensure it is securely terminated.
- 5) Repeat above steps 2-4 for L2 and N conductors.
- 6) Dress conductors with cable ties, ensuring even bends and sufficient strain relief.

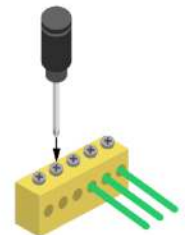

Figure 23 EGC ground bus connection

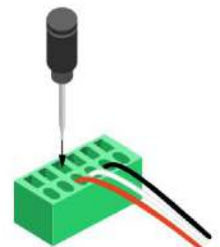

Figure 24 AC grid conductor connections

The opposite end of these conductors are terminated at an over current protection device in the main distribution panel. The table below contains the recommended over current protection rating.

Table 6 OCPD recommendations

Inverter Model	Over Current Protection Rating
TSI-7.6K-US	40A (bi-directional)
TSI-11.4K-US	60A (bi-directional)

AC Backup Connections – Battery systems only

Tools required: 1/8" flat screwdriver, #2 Philips screwdriver, cable ties

This section refers to the wiring between the inverter and the EI Automatic Transfer Switch (ATS). The ATS must be securely mounted before wiring is to take place. Refer to the ATS manual for instructions on mounting prior to completing the wiring described in this section. The TSS-50-US manual can be found by scanning the QR code to the right or at the following link:



<https://www.tigoenergy.com/product/ats>



Note – TSS-50-US

The ATS is used to supply energy to essential loads in the case of a grid outage. Before making the ATS connection, a subpanel for essential loads should be installed. Rewire the essential loads from the main distribution panel to this subpanel.

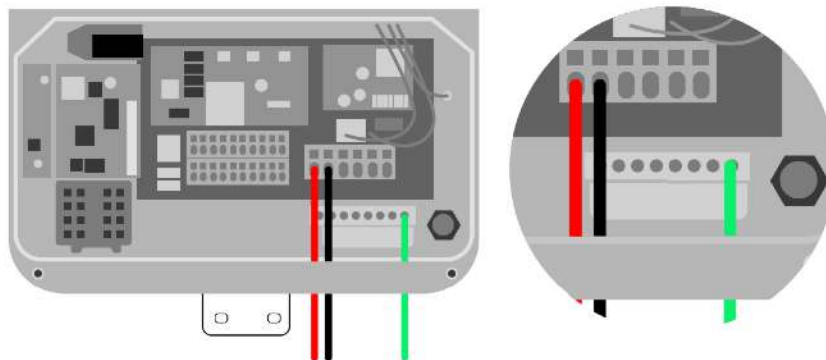

L2	L1	L1	N	L2
BACKUP		GRID		

Figure 25 AC Backup connections

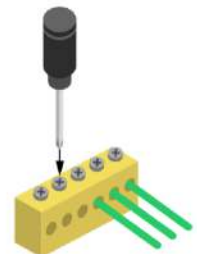

Figure 26 EGC Ground bus connection

- 1) Insert the EGC into the Grounding terminal and torque the set screw to 1Nm.
- 2) Insert the 1/8" standard flat blade screwdriver into the square hole above the L1 wire terminal, pressing to open the clamp.
- 3) Insert the L1 conductor into the appropriate wire terminal according to the labels and remove screwdriver to clamp the conductor.
- 4) Gently tug the conductor to ensure it is securely terminated.
- 5) Repeat above steps 2-4 for L2 conductor.
- 6) Dress conductors with cable ties, ensuring even bends and sufficient strain relief.

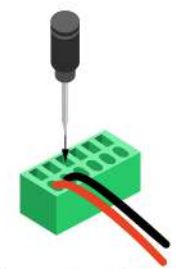

Figure 27 AC Backup conductor connections

PV Connections

Prior to making the wiring connections between the EI Inverter and array, first install the TS4 module-level power electronics (MLPE) on the PV modules. Tigo offers different TS4 products to meet individual project needs.

TS4 Introduction

The TS4 Flex MLPE platform is incremental in functionality. Select the TS4 version with features that best address the needs to the project.

Rapid Shutdown, Module-level Monitoring, Optimization

TS4-A-O

- NEC 2017 & 2020 690.12 Rapid Shutdown compliant
- Automatic shutdown (with grid-tied-only inverter)
- Manual shutdown with e-stop when installed in the Tigo EI storage system
- Module-level monitoring through the Energy Intelligence portal and mobile app
- Module-level optimization with Tigo's patented Predictive IV and impedance matching technology



Figure 28 TS4-A-O

Rapid Shutdown

TS4-A-F

- NEC 2017 & 2020 690.12 Rapid Shutdown compliant
- Automatic shutdown (with grid-tied-only inverter)
- Manual shutdown with e-stop when installed in the Tigo EI storage system



Figure 29 TS4-A-F

TS4 Installation

Supplies required: TS4s, cable ties/clips or other appropriate wire management hardware

The TS4 series of MLPE mount to the PV module by sliding on to the module frame. The TS4 mounting clips contain “teeth” that will secure the TS4 and provide bonding to the metallic frame of the PV module. No equipment grounding is necessary.

	<p>Note: For proper mounting, the module frame must be 1.2-3mm thick and engage with the module to a depth of 22mm minimum.</p>	
	<p>To allow for proper alignment and cooling the module must have a depth from module lip to backsheet of 30mm minimum.</p>	

	<p>Caution! Do not drill additional mounting holes in the frame or metal bracket.</p>
	<p>Always connect the PV module to the TS4 input <u>before</u> connecting the outputs in series. Otherwise, damage to the TS4 may occur.</p>

- 1) Mount the TS4 to the back of the PV module on the top edge.
 - a. The TS4 may be mounted to the side edges of the module but shall never be placed on the bottom edge with the cable glands facing up.
 - b. For installation with frameless modules, remove the metal mounting clips with a flat-blade screwdriver to reveal the mounting holes. These holes may be used to mount the TS4 to the racking structure. Use mounting hardware supplied by the specific racking manufacturer.
 - c. **TS4-A-O only:** The TS4-A-O includes a removable barcode (or QR code). This is used to identify the MLPE when mapping the system during commissioning. Remove this barcode and place on the grid located on the last page of the EI Inverter Quick Start Guide per the azimuth and layout of the array.



Figure 30 TS4 Mounting

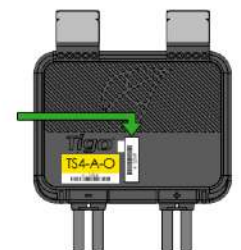

Figure 31 TS4-A-O barcode

- 2) Connect the PV modules to the TS4 inputs.
 - a. Secure conductors to prevent damage from movement, rodents, or accidental contact.
 - b. **Each TS4 must have a PV module connected to its inputs before connecting the output conductors of the TS4 units in series (string connections).**

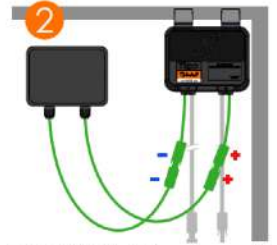

Figure 32 TS4 Module Connections

- 3) Connect the TS4 output conductors in series to create the PV string.
 - a. Secure conductors to prevent damage from movement, rodents, or accidental contact.

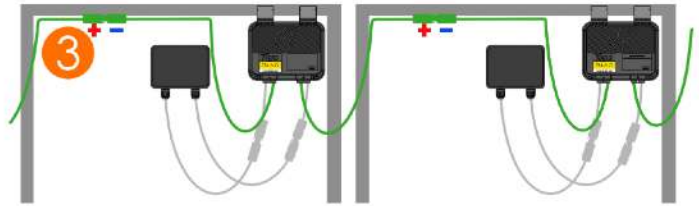

Figure 33 TS4 String connections

The TS4-A-F MLPE operate when receiving a “keep-alive” signal sent by powerline communication over the DC PV conductors. This signal is generated in the inverter and applied to the PV conductors once terminated in the inverter and the inverter is turned ON; no additional components are required.

The TS4-A-O MLPE are in the ON state from initial installation. To activate the rapid shutdown function, the Tigo Access Point must be installed. This is described in the following sections.

Tigo Access Point (TAP)

The TS4-A-O MLPE require the installation of the Tigo Access Point (TAP) to achieve rapid shutdown and module-level monitoring functionality. The TAP is the point of communication between the inverter and the MLPE. In most cases, only one TAP is required. The Tigo TAP Placement Tool can be used to help determine the best location and number of TAPs required for a particular installation: <https://smart.tigoenergy.com/tap/>

TAP Installation

Supplies required: TAP

	<p>Note: Wireless signal range can be affected by solid obstructions. Refer to the TAP placement guide for additional information. https://smart.tigoenergy.com/tap/</p>
--	---

The TAP mounts on the back of a centrally located PV module.

- The maximum distance between any two TS4-A-O that can be served by the same TAP is 33ft (10m).
- The maximum distance between the TAP and the farthest TS4-A-O is 115ft (35m).
- Up to 300 TS4-A-Os can be configured to 1 TAP if the above conditions are met.
- If additional TAPs are required due to split arrays, multiple TAPs can be wired in series.

TAP placement example:

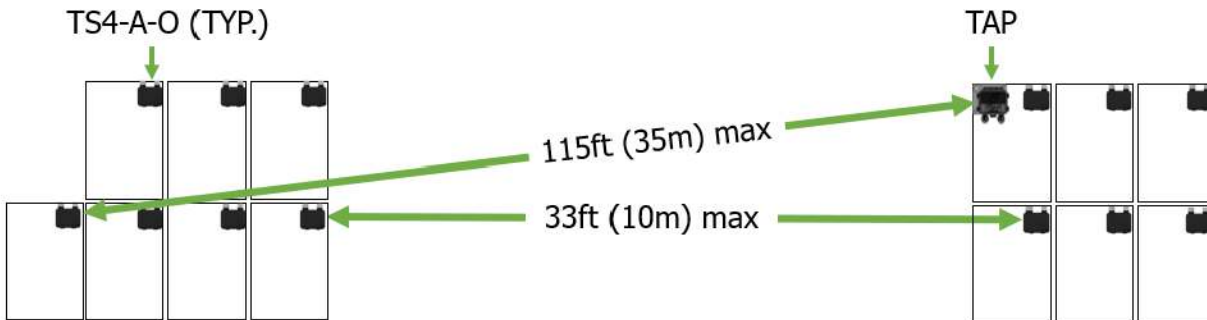

Figure 34 TAP Placement

The TAP attaches to the module frame using the built-in bracket. Mounting holes are also available for use with frameless modules.

Place TAP within 10m of any TS4-A-O in the array, with a maximum distance of 10m between TS4-A-Os and 35m from TAP to farthest TS4-A-O.



Figure 35 TAP Mounting

TAP/Communications conduit

Supplies required: 3/4" conduit and associated fittings

The left COM port (9) is used for multiple communications connections; e-stop, TAP, energy meter. Make sure to plan for the additional connections that will need to enter this port. Run conduit to Com port (9) and use appropriate fittings to ensure a water-tight fit.

Wiring the TAP

Tools required: 1/8" flat screwdriver

Supplies required: 4-conductor RS485 (18-22AWG), cable ties

	<p>Note: If multiple TAPs are required in the system, remove the terminating resistor from all TAPs between the last (furthest) TAP and the inverter. The TAPs will be daisy-chained using these terminals. The last TAP of the chain must have the terminating resistor between terminals A and B.</p>
---	--

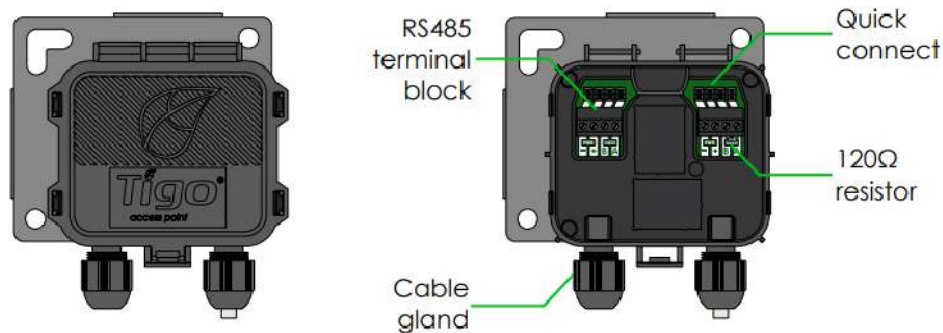

Figure 36 TAP Overview

Use 4-conductor RS485 (18-22AWG) cable with shield between TAP and inverter. If multiple TAPs are required connect the TAPs in series.

- 1) Run the RS485 cable from the TAP down to the inverter.
- 2) Strip approximately 1.2in (3cm) of the outer jacket of the cable. **The individual conductors do not need to be stripped, only the cable jacket.**
- 3) Connect black to -, red to +, blue to B and gray to A on the TAP terminals.
- 4) The TAP includes standard screw wire terminals or quick connect terminals:
 - a. To connect using the screw terminals: Insert the conductors into the appropriate terminal and tighten, using the 1/8" screwdriver, to 0.34Nm/3.04lb-in.
 - b. To connect using the quick connect terminals: Use the 1/8" flathead screwdriver included in the TAP package to press the conductors into the quick connectors.

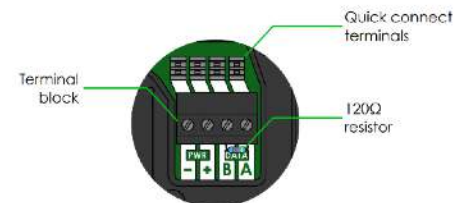

Figure 37 TAP Terminals

One terminating resistor comes with each TAP, terminated between the A and B data terminals. Only the last TAP in the series should contain this terminating resistor.

At the inverter, the RS485 terminates on the communication board above the DC disconnect using a 4-pin connector. This 4-pin connector comes connected to its terminal. Remove the connector from the terminal to complete the wiring.

Insert the wires in the same order as the TAP: (from top to bottom) Gray (A), Blue (B), Red (+), Black (-). Insert the 4-pin connector into the terminal as shown:

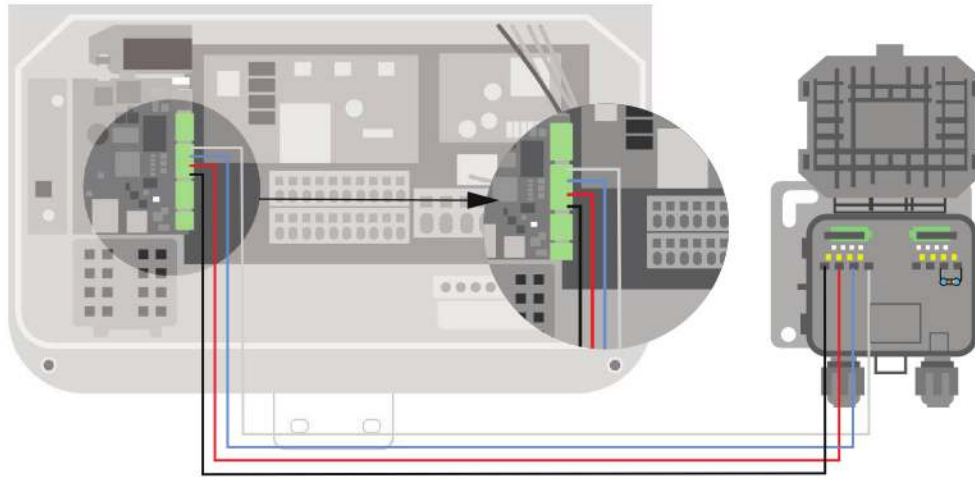

Figure 38 TAP-Inverter connection

DC Connections

The EI Inverter has a wide DC operating voltage range (50-550V_{DC}), 3-MPPTs in the TSI-7.6K-US and 4-MPPTs in the TSI-11.4K-US. This provides for many string combinations offering optimal performance.



Caution!

Follow NEC 690.7 and the PV module manufacturer specified V/Temp coefficient to ensure PV string voltage is less than 600V_{DC} for all possible weather conditions at the installation location.

DC Conduit

Supplies needed: 1" conduit and associated fittings.

The left DC conduit opening (**5**) is reserved for the inverter's PV input conductors for connection to the PV array. This conduit hole should have been opened prior to mounting the inverter. If not, make sure the inverter is securely mounted and the cover removed before drilling open the conduit drill guide and use caution to not come in contact with any internal components.

Route the conduit between the inverter and the PV array. Use appropriate conduit fittings to ensure a water-tight seal. Bond any metallic conduit, as required.

The right DC conduit opening (**6**) is reserved for the DC battery input conductors which connect to the EI Battery in battery installations. If installing the EI Battery, route the conduit from the right conduit opening to the EI Battery. Use appropriate conduit fittings to ensure a water-tight seal. Bond any metallic conduit, as required.

Conductor preparation

Tools required: wire cutter, wire stripper, crimping tool, conductor labels/marketing method



Supplies needed: AC conductors, wire ferrules (L)

The DC power conductors are terminated in the EI Inverter via pressure terminals. These terminals clamp on to the exposed end of the conductor. To ensure a reliable connection always use wire ferrules (L) on the end of these conductors.

- 1) Run the DC conductors and EGCs through the appropriate DC conduit.
- 2) Strip 5/8in (16mm) of insulation from the end of the PV+, PV- conductors. If installing an EI Battery, strip 0.7in (18mm) of insulation from the end of the BAT+ and BAT- conductors.
- 3) Use the crimping tool to connect the wire ferrules (L) to the conductor ends that will be terminated in the EI Inverter.
- 4) Label all conductors.

Connecting the PV Strings

Tools required: 1/8" flathead screwdriver, #2 Philips screwdriver, cable ties

	<p>WARNING! Improper operation during the wiring process can cause fatal injury to operator or unrecoverable damage to the inverter. Only qualified personnel may perform the wiring of the inverter.</p>
	<p>The output wiring terminals of PV modules or TS4 MLPE connected to the PV modules may have hazardous voltages. Touching the terminals may cause electric shock. Before connecting the PV strings, ensure the DC disconnect switch is OFF and that the DC input terminals have no voltage.</p>
	<p>When the inverter is operating, do not connect or disconnect PV strings or PV modules in a string, due to the risk of electric shock.</p>
	<p>Both positive and negative conductors must be electrically isolated from the ground (PE).</p>
	<p>Risk of electric shock and fire. Use only with PV modules with a maximum system voltage of 600V_{DC} or higher.</p>
	<p>Caution! Due to the transformerless design, PV strings connected to this inverter must not be grounded. Ensure the PV module conductors and string conductors are well isolated from ground.</p>

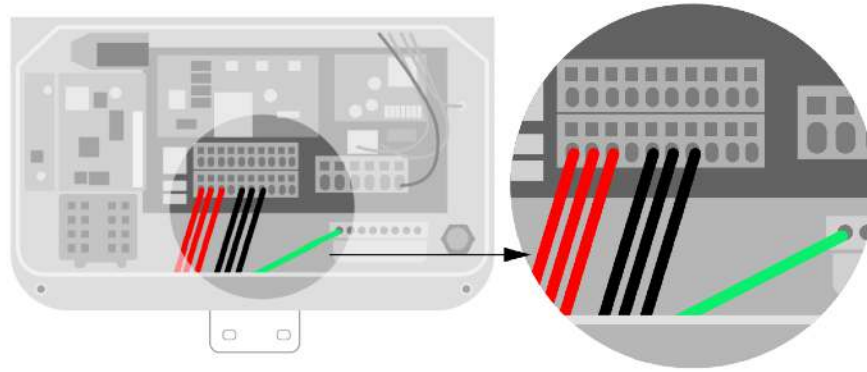

1	2	3	4	1	2	3	4	+	-
PV+				PV-				BAT	

Figure 39 PV connections

- 1) Turn the DC disconnect to OFF.
- 2) Insert the ground conductor into the ground bus and tighten the set screw to 1Nm.
- 3) Insert the 1/8" flat screwdriver into the square hole above the conductor terminal and press to release the clamp.
- 4) Insert the string conductor into the appropriate terminal block round opening according to the terminal block label (PV+1/2/3/4, PV-1/2/3/4).
- 5) Remove screwdriver to clamp the conductor.
- 6) Gently tug to ensure the conductor is securely connected.
- 7) After terminating each string, verify the polarity between the input terminals. Note the voltage of each string.
- 8) Repeat steps 3-7 for all strings.
- 9) Dress conductors with cable ties, ensuring even bends and sufficient strain relief.

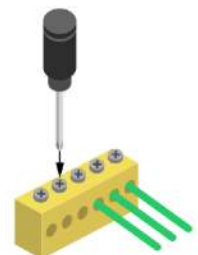

Figure 40 EGC Ground bus connection

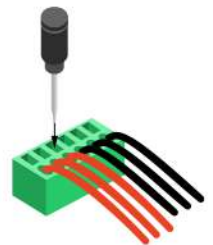

Figure 41 PV string connections

The DC voltage of each string must be less than 600V_{DC} under any operating condition. Depending on the model of TS4 installed, the PV string voltage will be either the operating voltage, or a safety voltage.

The TS4-A-F will output 0.6V per module in safety mode. To know the number of modules connected in series divide the measured string voltage by 0.6V.

$$\text{No. of PV modules} = \frac{\text{String voltage}}{0.6V}$$



The TS4-A-O models output full string voltage before they are commissioned with the inverter. After which, these models will enter rapid shutdown only when the rapid shutdown command is initiated.

Battery Connections

Tools required: 1/8" flathead screwdriver, cable ties

Prior to making the wiring connections between the EI Battery and EI Inverter, first securely mount the battery enclosure(s) in place and install the battery modules. Details on these connections and mounting instructions can be found in the TSB manual found here: <https://www.tigoenergy.com/product/ei-battery>



	<p>Warning! Battery short circuits may cause personal injury. The high transient current generated by a short circuit will release a surge of energy and may even cause fire.</p>
	<p>To prevent the risk of electric shock, do not connect or disconnect battery cables when the inverter is running.</p>
	<p>Before connecting battery cables, ensure the DC switch on the inverter and all switches connecting the inverter are in the OFF position, and the inverter contains no residual electricity. Otherwise, the high voltage of the inverter and battery may result in electric shock and/or damage to the inverter.</p>
	<p>Exposure to battery voltage can result in serious injury. Use dedicated insulated tools and proper PPE to connect conductors.</p>
	<p>Caution! Make sure the battery conductors are properly connected: Positive and negative terminals of the battery connect the positive battery terminal and negative battery terminal on the inverter respectively.</p>
	<p>Do not connect loads between the inverter and the battery. Since the inverter is transformerless, the battery connected to the inverter cannot be grounded. Ensure the battery output is well insulated from ground.</p>
	<p>Note: A fused disconnect switch can be configured between the inverter and battery to ensure the inverter can be safely disconnected from the battery. The recommended DC fuse type is Littlefuse KLKD 600V/30A. Make sure the battery positive cable connecting to the positive fuse holder and positive pole of the switch in series. The battery's negative conductor connecting to negative fuse holder and negative pole of the switch in series.</p>
	<p>The cable distance between the battery and the inverter should be less than or equal to 10 meters, ideally less than 5 meters.</p>

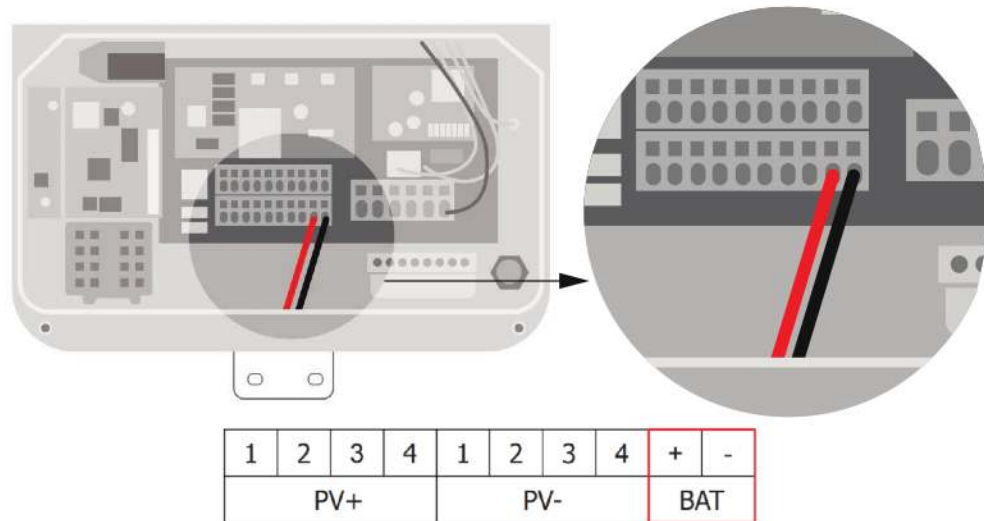

Figure 42 Battery connections

- 1) Strip 0.6in (15mm) of the battery conductor insulation.
- 2) Identify the conductor's appropriate terminal according to the labels on the terminal block (BAT+, BAT-).
- 3) Insert the 1/8" standard flat-blade screwdriver and press the release mechanism to open the BAT- clamp.
- 4) Insert the negative conductor into the round opening of the BAT- terminal and remove the screwdriver to clamp the conductor.
- 5) Gently tug the conductor to ensure it is securely terminated.
- 6) Repeat steps 2-5 for BAT+ conductor.
- 7) Dress conductors with cable ties, ensuring even bends and sufficient strain relief.

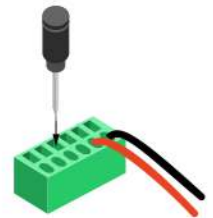

Figure 43 Battery connections

Battery Communications Connection

Tools required: wire cutter, RJ-45 crimping tool, conductor labels/marketing method

Supplies needed: CAT5/6, 2 RJ-45 jacks, 3/4" conduit and associated fittings

The EI Battery and EI Inverter must communicate to operate. This communications connection requires a CAT5/6 cable and RJ45 connectors.

The right COM conduit opening (**10**) is reserved for the battery communications cable which connect between the EI Inverter and EI Battery in battery installations. If installing the EI Battery, route the conduit from the right conduit opening to the EI Battery. Use appropriate conduit fittings to ensure a water-tight seal. Bond any metallic conduit, as required.

CAT5/6 cables have 8 wires (four twisted pairs). Two wiring standards exist: T-568B and T-568A, as shown below. Either standard may be used, as long as both ends of the cable use the same wiring standard.

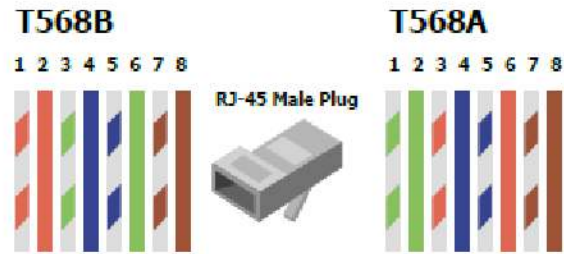

Figure 44 RJ-45 wiring diagram

Table 7 Battery communications wiring schedule

RJ45 Pin #	Wire Color		Signal	Function
	T568B	T568A		
1	White/Orange	White/Green	Enable +	Battery wake-up signal
2	Orange	Green	Enable -	
3	White/Green	White/Orange	CANL	Battery CAN communication
4	Blue	Blue	CANH	
5	White/Blue	White/Blue	GND	GND
6	Green	Orange	Received	NC
7	White/Brown	White/Brown	RS485B	Battery RS485 communication
8	Brown	Brown	RS485A	

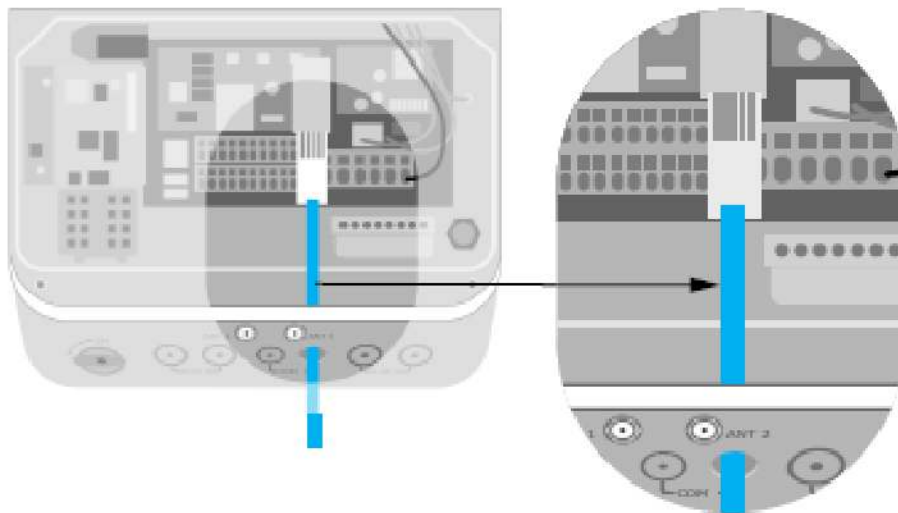

Figure 45 Battery communications connection

- 1) Using a cable cutter/stripper, remove 0.5in (1.2cm) of external insulation/jacket from the CAT5/6 cable, exposing the 4 twisted pairs of wire.
- 2) Untwist approximately 0.5in of the end of the wires and insert the eight wires into an RJ45 connector. Choose either T-568A or T568B standard for wiring – stay consistent.
Note – the individual wires do not need to be stripped.
- 3) Crimp the connector with the appropriate crimping tool.
- 4) Plug the RJ45 connector into the RJ45 port on the communications board inside the inverter.
- 5) Repeat the wiring process on the battery end of the cable, following the same wiring standard used for the inverter connection.
- 6) Inset the RJ45 connector into the inverter COM port on the left side of the battery enclosure.

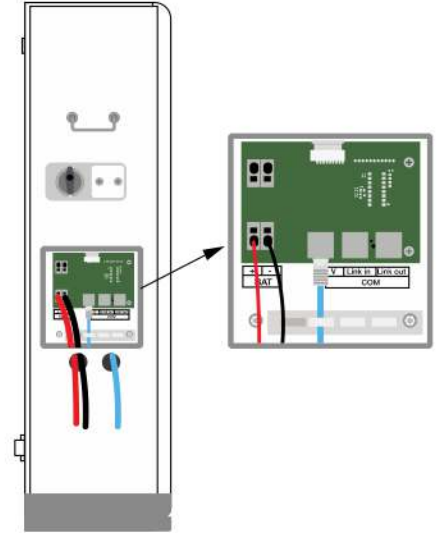

Figure 46 Battery connections (from EI Battery)

Rapid Shutdown Initiator

Rapid Shutdown is required for any rooftop PV system governed by the National Electric Code since 2014. The EI Inverters paired with the TS4-A-F and TS4-A-O are UL PVRSS (PV Rapid Shutdown System) certified.

The initiation of rapid shutdown, per Code, may be either manual (e-stop button) or automatic (loss of grid). The type of PV system being installed will dictate the initiation options available.

Only one method may be labeled as the RSD Initiator.

System	Loss of Grid	E-Stop
EI Inverter only (grid-tied)	✓	✓
EI Inverter + battery		✓

Apply the yellow label (C) at the service entrance of which the system is connected.

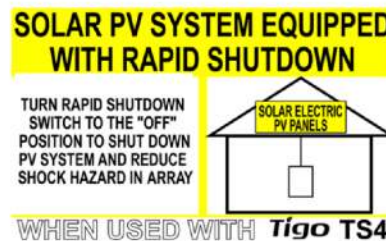



Figure 47 Rapid Shutdown label

E-Stop Installation

Tools required: Drill, M6 drill bit, 1/8" flathead screwdriver, #2 Phillips screwdriver, hammer/mallet

Accessories required: E-stop button (D), wall anchors (O), self-tapping screws (N)

	<p>Note: The E-Stop button (D) is required for the activation of rapid shutdown in the battery storage PV system. The instructions below are for mounting the E-Stop to drywall. If another mounting surface is used, use appropriate hardware to securely mount the enclosure.</p>
---	--

The emergency stop (E-stop) button (D) included with this inverter is used to stop the PV modules from passing voltage on the string conductors, leaving them at a safe voltage for first responders to perform work in or on the building.

The e-stop button is a normally closed (NC) contact. When the button is pushed, the state of the e-stop is open.

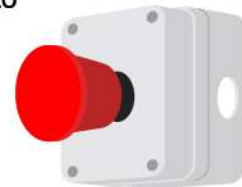

Figure 48 RSD E-stop button

- 1) Use a #2 Phillips screwdriver to loosen the 4 plastic screws of the assembled e-stop enclosure. Separate into two parts.
- 2) Use the template in the Appendix of this document and an M6 drill bit to drill out pilot holes for the mounting screws.
- 3) Insert the wall anchors (O) into the 4 holes and tap with a mallet to bring flush with the wall.
- 4) Align the holes in the lower half of the e-stop enclosure (D) with the positions of the wall anchors. Use the 4 self-tapping screws (N), or other appropriate mounting hardware depending on the surface, to secure the enclosure to the wall.

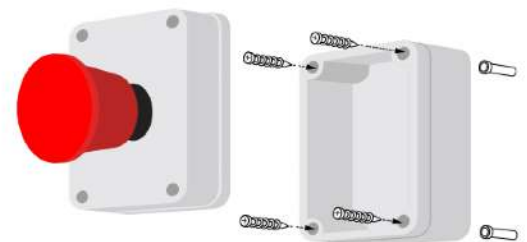

Figure 49 RSD E-stop button mounting

E-Stop wiring

Tools required: 1/8" flathead screwdriver, #2 Phillips screwdriver, cable ties

Supplies required: conduit and associated water-tight fittings, two 18-22AWG conductors

The left COM port (9) is used for multiple communications connections; e-stop, TAP, energy meter. If conduit has not already been installed with accommodation for the e-stop wiring,



install this now. Make sure to plan for the additional connections that will need to enter this port and use appropriate fittings to ensure a water-tight fit.

Two 18-22AWG conductors are used for the connection between the e-stop and inverter. At the inverter these conductors are terminated at a 3-pin connector on the left side of the communications board. At the e-stop, the conductors are connected to the back of the contactor.

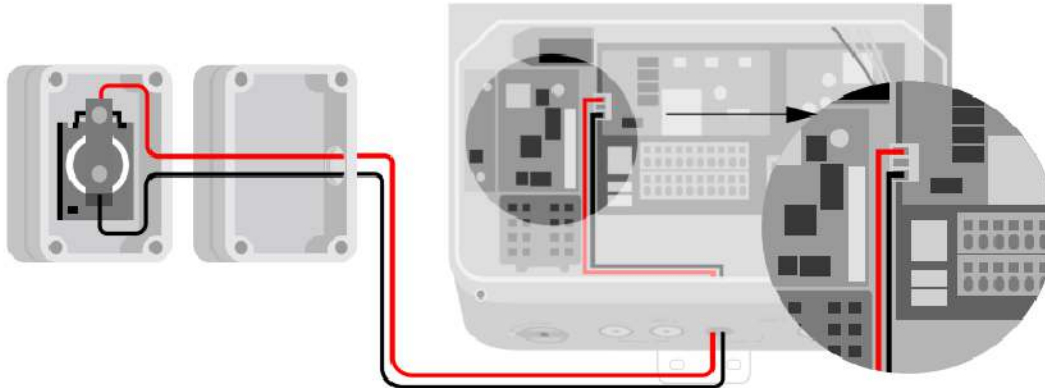

Figure 50 E-Stop connections

- 1) Pass the two power conductors through the conduit between the inverter and e-stop.
- 2) Remove the 3-pin connector from the CN14 port.
 - a. Remove the jumper wire from the 3-pin connector.
 - b. Connect the two conductors to the 3-pin connector in positions 1 and 3 (position 2 is open). Polarity is not important.
- 3) Insert the 3-pin connector into port CN14.
- 4) Connect the conductors to the e-stop contacts as shown in Figure 46.
- 5) Replace the e-stop cover and tighten with the 4 plastic screws.

Energy Meter

The energy meter provides important information about the building's energy usage. When installed in the Tigo EI Solution this data used to help dictate the state of operation for the battery. The energy meter data is also displayed in the EI Platform, providing visibility of when the EI system is importing or exporting energy.



Note:

The energy meter is required when installing the EI system with batteries. This meter is optional when installing in a grid-tied-only application. The meter is to be ordered separately from the EI Inverter.

Before connecting to the inverter, refer to the Energy Meter installation manual for specifications and additional information on installing this device. The Energy meter manual can be found here: <https://www.tigoenergy.com/downloads> or by accessing the QR code to the right.



Meter Installation

Tools required: Drill and bit

Supplies required: 35mm DIN rail, 2 DIN rail end stops, energy meter

The meter should be mounted in the load center/service entrance.

Mount the meter on a 35mm DIN rail (not included).

Install DIN rail end stops on each side of the meter to secure the meter in place (not included).

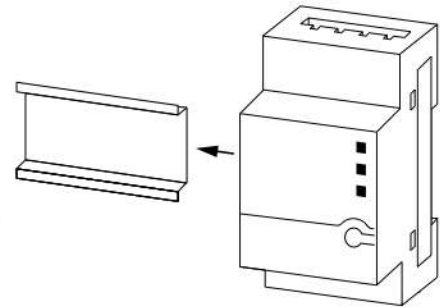

Figure 50 Energy Meter

Wiring the Meter

Tools required: 1/8" flathead screwdriver, cable ties

Supplies required: conduit and associated water-tight fittings, two 18-22AWG conductors, 10-20A over current protection device

	Note:
	When installing the energy meter (required for battery installs) note that the CT conductor length is 80 inches. THESE MUST NOT BE CUT OR SPLICED. Core arrows must face away from the grid.

The energy meter includes 2 CTs which monitor the current and direction of energy flow from the grid. Three conductors terminated at an over current protection device in the main service panel monitor the grid voltage. This data is sent to the inverter via a 3-wire CAT5/6 cable.

Table 8 Energy meter cable/conductor schedule

Cable/Conductor	Meter position	Inverter	Type	Conductor size
AC conductor – L1	L1 (8)	N/A	Solid or stranded. Never use fine stranded conductors.	22-18AWG
AC conductor – L2	L2 (9)			
AC conductor – N	N (10)			
Ground	PE Symbol			
CT – L1	+/- L1 (6, 7)	N/A	Included with meter	N/A
CT – L2	+/- L2 (4, 5)			
Communications	A+	See image	Min. 3-wire shielded twisted pair.	24-18AWG
	B-			
	GND			

	<p>Note: A Belden 3074 is recommended for the energy meter connection to the EI inverter. https://www.belden.com/dfsmedia/f1e38517e0cd4caa8b1acb6619890f5e/9523-source/options/view</p>
--	--

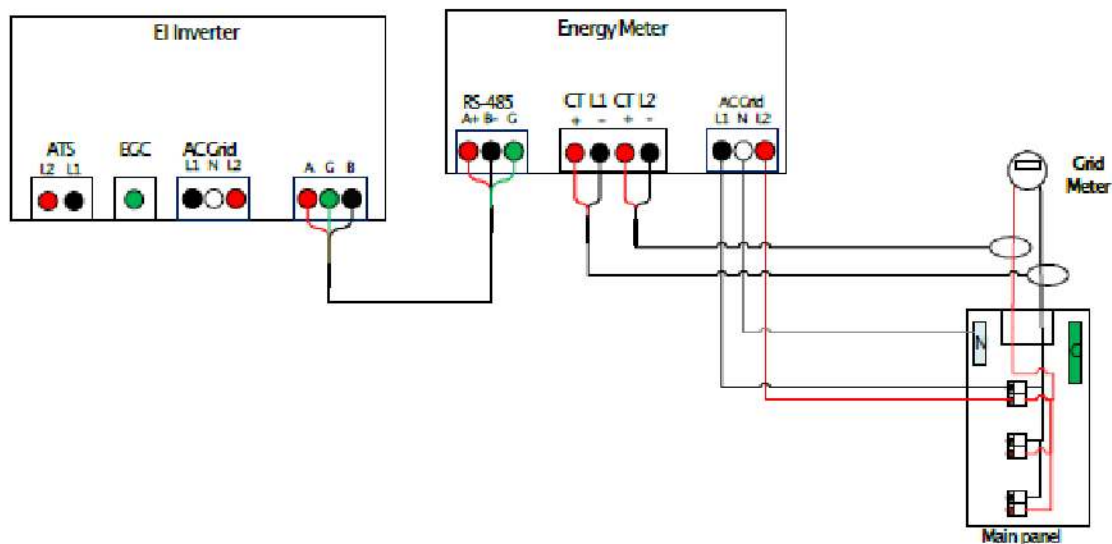

Figure 51 Energy Meter wiring diagram

This meter is considered “permanently connected equipment” and requires a disconnect means. The meter draws 10-30mA therefore the rating of the overcurrent protection is based on the size of the conductors used. Use a circuit breaker or fuse rated for 20A or less.

	<p>Note: The overcurrent protection and disconnecting means must meet all national and local electric code requirements. In the rare occasion in which the neutral requires overcurrent protection, the device must interrupt both neutral and ungrounded conductors simultaneously. If using communication cable longer than 33ft/10m in areas with risk of induced voltage surges due to lightning, it is recommended to use external surge protective devices. If grounded metallic conduit is used for routing of the communication conductors, a lightning protection device is not required.</p>
--	---

- 1) Verify the power is OFF before making connections.
- 2) Connect the AC conductors to the 4-pin connector.
 - a. Loosen the appropriate screws on the 4-pin connector.
 - b. Connect each AC conductor to the appropriate screw terminal of the connector:
L1 – red, L2 – black, neutral – white, ground - green



- c. Tighten the screws 0.4Nm, making sure the conductors are fully inserted and cannot be easily pulled out.
 - d. Insert the 5-pin connector into the terminal on the meter making sure it is fully seated.
 - e. Complete the installation of the AC conductors by terminating the opposite end of the conductors at an overcurrent protection device (20A or less) in the load center.
 - 3) Connect the CT conductors to the 4-pin connector of Block 1:
 - a. Loosen the pins of the 4-pin connector of Block 1.
 - b. Connect the blue and brown conductors to the connector as shown in the diagram:
CT1 blue – 1, CT1 brown – 2, CT2 blue – 3, CT2 brown – 4
 - c. Tighten the screws making sure the conductors are fully inserted and cannot be easily pulled out.
 - d. Insert the 4-pin connector into the Block 1 terminal on the meter making sure it is fully seated.
 - e. Clamp the CTs around the Grid conductors feeding the main service panel:
CT1 – L1, CT2 – L2
 - f. Secure the clamping CTs with a cable tie to ensure it does not become loose or open.
 - 4) Connect the RS485 twisted pair cable to the 4-pin connector of Block 2:
 - a. Loosen the pins of the 4-pin connector of Block 2.
 - b. Connect conductors to the A+, B-, and GND positions on the connector
A+ red - 2, B- black - 3, shield green – 4 (position 1 is open).
 - c. Tighten the screws making sure the conductors are fully inserted and cannot be easily pulled out.
 - d. Insert the 4-pin connector into the Block 2 terminal on the meter making sure it is fully seated.

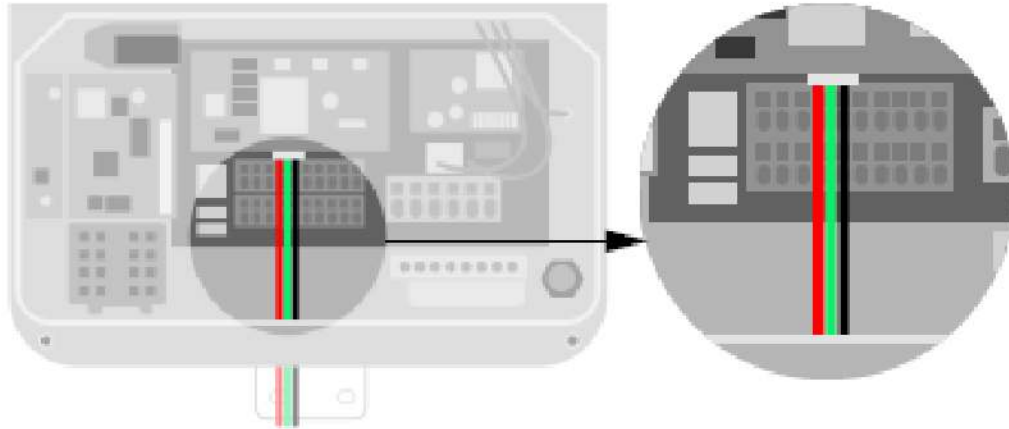

Figure 52 Energy meter communications connection

- 5) Connect the RS485 twisted pair cable to the 3-pin connector in the inverter:
 - a. Run conduit from the load center to the inverter. Use appropriate conduit fittings to ensure a water-tight seal.
 - b. Loosen the pins of the 3-pin connector included with the inverter accessories (**J**).
 - c. Connect conductors to the A+, B-, and GND positions on the connector
A+ red - 1, shield green – 2, B- black - 3
 - d. Tighten the screws making sure the conductors are fully inserted and cannot be easily pulled out.
 - e. Insert the 3-pin connector into the inverter’s 3-pin terminal on the communication board making sure it is fully seated.

Meter Status Indication

The front of the meter contains 3 LEDs to help indicate current measurement and operation. At normal startup, when power is first applied, all LEDs light up sequentially for 1 second.

Table 9 LED Power Status

LED	LED Color	Function	Indication	Troubleshooting
RUN	Green	Flashing ON/OFF (for 1 sec)	Normal operation	N/A
	Red	ON for > 3 sec.	Internal error	Contact support
	Yellow	Flashing ON/OFF (for 1 sec.)	No communication	Check the communication conductors are properly connected

Table 10 LED Phase Status

LED	LED Color	Function	Indication	Troubleshooting
L1/L2	Green	ON for > 3sec.	No current	
		Flashing ON/OFF (for 1 sec.)	Positive power	
	Red	Flashing ON/OFF (for 1 sec.)	Negative power	Check for reversed CTs, swapped CT conductors, or CTs not matched with the lines.
		Flashing with green LED	High voltage > 130V	Check the line voltages and the meter rating.
		Flashing with yellow LED	Low voltage < 70V	
	Yellow	Flashing ON/OFF (for 1 sec.)	Break fault < 30V	
		ON for > 3 sec.	Frequency is below 45Hz or above 70Hz	Check for the presence of high noise.

Antenna Connections

Supplies required: WiFi antenna (**E**), Optional-Cellular antenna (**F**)

The EI Inverter primarily communicates to the Cloud over WiFi. A cellular backup is available as an optional feature from Tigo. Each connection requires a different antenna.

The WiFi antenna (**E**) is provided with the inverter accessories. This antenna allows for the commissioning to the inverter for commissioning as well as monitoring and communication of the inverter to the Tigo Cloud.

A cellular antenna (**F**) is provided with cellular equipped models only. Cellular data is used as a back-up when WiFi is down.

The WiFi antenna (**E**) connects to ANT1 (**7**) and the cellular antenna (**F**) connects to ANT2 (**8**). The antennas screw on to the ANT connectors at the bottom of the wirebox.



Figure 53 WiFi antenna



Figure 54 Cellular antenna

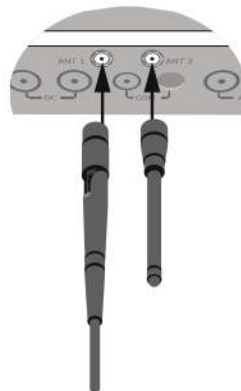



Figure 55 Antenna connections

Commissioning

The EI Inverter uses the Tigo EI mobile App to commission the inverter. If not already downloaded on a mobile device, scan the QR code to access the latest EI app for Android and iOS. This QR code is also located on the side of the inverter on the specifications label.



	<p>Caution! High voltages in the PV system. Risk of serious injury due to electric shock. Only electrically qualified personnel may perform work on the PV system.</p>
	<p>Warning! Make sure the maximum open circuit voltage of any string connected to this inverter is less than 600V_{DC} under any condition.</p> <p>Read all instructions, cautions and warnings for the EI Inverter and connected devices.</p> <p>Installation and commissioning must be performed by a licensed electrician or other qualified person in accordance with local, state and National Electric Code ANSI/NFPA 70 requirements.</p> <p>Verify the input polarity with a voltmeter (min 600V_{DC} rated) with the disconnect in the OFF position.</p>

Pre-power Check

Use the following check list prior to powering on the inverter.

Table 11 Pre-power checklist

✓	Item	Acceptance
	Inverter Installation	The inverter is installed correctly and securely.
	Conductor layout	Conductors are routed properly, and good wiring practices are used throughout the system.
	Cable ties	Cable ties are secure and have no sharp edges.
	Conductor connections	The inverter output, PV input, battery and communications conductors are connected correctly and securely.
	Proper Torque	All screw/bolt connections are properly torqued to the specifications in the Torque Table below.
	Conduit fittings	All conduit attachments are sealed and secure.
	Grounding	Ground conductors are connected correctly and securely.
	Unused terminals/ports	Unused conduit openings are fitted with water-tight caps or left unopened.
	Disconnect Switches	All disconnect switches in the system are in the OFF position.
	Clean wireboxes	The interior wirebox of the inverter and all other installed equipment is clean and tidy.
	Installation environment	The area around the inverter, and other system components has been left clean and accessible.
	Antenna Installation	The antenna(s) is installed correctly and securely. Two antennas required when cellular backup is used.



Torque Table

Table 12 Torque table

Energy meter	0.4Nm
EI Battery enclosure cover	1.0Nm
ATS Load	3.5Nm
ATS Grid/Backup	2.5Nm
Inverter ground bar	1.0Nm
Inverter cover	1.5Nm

Powering on the EI Solution



Warning!

Before powering on this system, ensure the appropriate PPE is being used, including insulated tools.

1. At the main service entrance, check the grid voltage is within the operating specifications of the inverter.
2. Turn on the AC disconnect switch and/or circuit breaker.
3. Confirm voltage of PV strings are less than 600V_{DC}.
4. Turn on the DC disconnect switch at the bottom of the inverter.
5. If a battery is installed:
 - a. Turn on the battery disconnect switch located on the left side of the battery enclosure.
 - b. If an additional disconnect was installed separately, turn this switch to on.
6. Open the EI App and complete the commissioning of the TS4s, inverter and battery.



Note:





All grid settings, modes of operation, and communications setup take place in the Energy Intelligence App.

Local WiFi must be present for data monitoring.

LED Status

Four icons act as status indicators.

Table 13 LED status

Icon	Designation	Color
	Power	Green
	Wireless communication (COMM)	Green
	Battery (BAT)	Green
	Fault	Red

These LEDs communicate different messages by the blinking of the different icons.

Table 14 LED Messages

LED Designation	Color	Status	Action	Message	
Power	Green	ON	Steady	Normal operation	
		Blink	3s on/1s off	DC ON / AC OFF	
			1s on/3s off	DC ON / AC OFF	
			0.5s on/0.5s off	Synchronizing with grid	
			2s on/2s off	Standby mode	
BAT	Green	ON	Steady	Battery is in normal operation	
		Blink	1s on/3s off	Battery is in low power	
			0.5s on/0.5s off	Battery is in fault mode	
			1s on/1s off	Battery internal comms error	
			2s on/2s off	Battery is in standby mode	
	Blank	ON	Steady	No Battery, PV inverter only mode	
	COMM	Green	ON	Steady	WiFi and Cellular connections ok
			Blink	0.5s on/0.5s off	Local WiFi connecting
1s on/1s off				Cellular error, local WiFi ok	
1s on/3s off				Local WiFi error, Cellular ok	
Blank		ON	Steady	Communications error	
FAULT	Red	ON	Steady with audible alarm	Arc Fault	
	Red	Blink	1s on/1s off	Warning	
	Red	ON	Steady	Fault	

The following combination of LEDs indicate the operational status of the inverter.

Table 15 LED Operational Status Messages

LED Designation	Color	Status	Action	Message
POWER	Green	ON	In sequence	DSP Firmware Update
BAT	Green	ON		
COMM	Green	ON		
FAULT	Red	ON		
POWER	Green	Blink	1s on/1s off	M3 Firmware Update
BAT	Green	Blink		
COMM	Green	Blink		
FAULT	Red	Blink		
POWER	Green	Blink	3s on/1s off	Backup mode
BAT	Green	ON	Steady	
BAT	Green	Blink	1s on/1s off	BAT internal communications error
COMM	Green	Blink		

Powering Off the EI Solution

	<p>CAUTION – Risk of Shock and burns! Wait 5 minutes before servicing the inverter. Always wear appropriate PPE when servicing the inverter.</p>
	<ul style="list-style-type: none"> • If a battery is connected, ensure the shutdown command is sent from the EI mobile app. • Power off battery system after the inverter has shut down. The app command prevents the inverter from entering backup mode. • Shut down grid, PV, and battery completely.

1. Open the EI App and send the "System Shutdown" command.
2. Open/turn off the AC disconnect switch between inverter and the service entrance.
3. Open/turn off the DC disconnect switch at the bottom of the inverter.
4. If a battery is connected, power off the battery

Reset Button

A reset button is located on the top right of the inverter’s communications board. This button performs multiple functions as described below in Table 16.

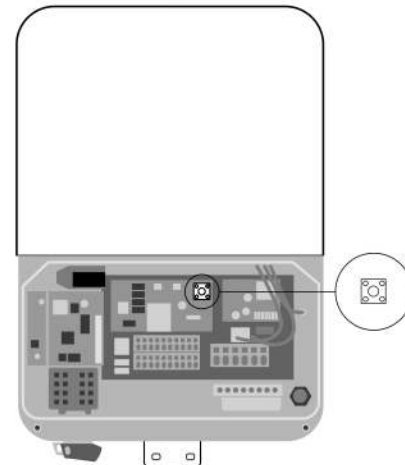

Figure 56 Reset button

Table 16 Reset functions

Function	Application	Action
Arc fault reset	Clear an arc fault notification	Press for 3-5 seconds
Arc fault self-test	Run an arc fault self-test when no arc fault alarm is present	
Communications reset	Communications reset to factory status	Press for >10 seconds

After Installation

Congratulations, the EI Solution has been installed! If the sun is out, it should be producing power.

Cleaning and Care

The EI platform is monitoring the inverter, battery, grid and TS4 module-level data (if TS4-A-Os are installed). If the inverter regularly reduces its output power due to high temperatures, improve the inverter’s heat dissipation. Solutions are likely to involve:

1. Provide shade to the inverter (do not enclose the inverter in a cabinet, or similar), or
2. Make sure the heat sink is free from debris such as bird nests.

If the inverter is dirty, a clean, damp cloth can be used to wipe down the front surface. Never use cleaning agents (e.g., solvents or abrasives).



Maintenance

Once per year, turn the DC disconnect switch on the inverter from the ON position to OFF, 5 times in succession. This cleans the contacts of the rotary switch, prolonging the electrical endurance of the DC disconnect.

If external damage is ever seen or reported, the installer or O&M company must investigate and contact Tigo.

Troubleshooting

If an issue does arise, many times it can be resolved by understanding the error code provided. The first level of communication is the LEDs on the front panel. Refer to Table 14, to decipher the LED Code.

If more information is required to understand the issue, open the EI mobile app to read the error code and description. Use the chat function within the EI mobile app to get real-time help on the issue you are experiencing.

A table of all error and warning codes can be found in the Tigo Help Center by following this link: <https://support.tigoenergy.com/hc/articles/4408751264531>

Your Tigo Customer Support contact

Contacting technical support may be required to assist with your installation or maintenance. If the system is commissioned, Tigo will have component-level data to help understand and resolve the issue. If the PV modules are not monitored, or the inverter is not communicating, additional information will be required.

Please be prepared to provide the following information if the inverter is not communicating to the Cloud.

From the inverter:

- Serial number
- Model number
- Error message from EI app / error code from LEDs
- Description of the issue
- Grid voltage
- DC input voltage
- Can the error be reproduced? If so, how?
- Has the problem occurred previously?
- What is/was the ambient conditions when this error occurred?



In addition to the inverter, the following information from the PV modules may be necessary. If the inverter is not communicating, or module-level monitoring was not installed, please provide the following:

- Manufacturer and model of the PV modules
- Module wattage
- Module Voc
- Module Vmp
- Module Imp
- Number of modules in each string

The Tigo Customer Support Team can be contacted in multiple ways:

- Chatting with a Customer Support tech through the EI App.
- Submitting a ticket directly in the Tigo EI App.
- Submitting a ticket through the Help Center: [Submit a request – Tigo Help Center \(tigoenergy.com\)](https://tigoenergy.com)
- Call 1-408-402-0202 (phone), 1-408-402-0805 (WhatsApp)
 - Support hours:
Monday – Friday
7:00am – 6:00pm PST (10:00am – 9:00pm EST)

You can always [Ask the Community](#). The Community is a web-forum consisting of peers to learn, share, and collaborate.



Discover the Community by clicking the link above or scan the QR code with a smart device.



Decommissioning

Removing the inverter

**WARNING – Risk of burns!**

Wait 20 minutes before disassembling until the enclosure has cooled.

1. Disconnect the inverter, as described in (Powering off the EI Solution).
2. Remove all conductors from the inverter, ensuring the exposed conductors are protected/safe.
3. Remove the conduit fittings.
4. Lift inverter up, off the bracket and away from the conduit.
5. Remove bracket from wall.

Packing the inverter

When possible, pack the inverter in its original packaging and secure with tension belts.

If this is not an option, find an equivalent carton. This box must be capable of being completely closed and constructed to support the weight and size of the inverter.

Storing the inverter

Store the inverter in a dry place where ambient temperatures do not exceed 22°F to 149°F (-30°C to 65°C).

Disposing of the inverter

Do not dispose of any inverter or accessory with household waste. Comply with local and state regulations for disposing of electronic waste.



Warranty

The warranty of the EI Inverter can be found at <https://www.tigoenergy.com/product/ei-inverter>



Input Data	7.6K	11.4K
Max. Recommended PV Power (STC)	15200W	22800W
Max. DC/AC Ratio	2	
Max. DC System Voltage	600V	
Startup Voltage	50V	
Nominal Voltage	360V	
Operating Voltage	50V~550V	
No. of MPPT	3	4
No. Of PV Strings per MPPT	2	2
Max. Input Current per MPPT (Imp / Isc)	13.5A / 16.9A	

Input/Output Data (Battery)

I/O Voltage Range	360V~550V
Nominal DC Voltage	400V
I/O DC Current	14.3A
I/O DC Power	5000W
Battery Technology	LFP
Battery Capacity per enclosure	9.9kWh or 19.8kWh

Output Data (AC)

AC Nominal Power@240V AC	7600W	11400W
AC Nominal Power@208V AC	6580W	9880W
Max. AC Apparent Power	7600VA	11400VA
Nominal AC Voltage	208V/240V	
AC Voltage Range @208V AC / @240V AC	183V~229V / 211V~264V	
AC Grid Frequency	50/60Hz	
AC Grid Frequency Range	45~65Hz	
Max. Output Current	32A	48A
Power Factor (@Normal Power)	>0.99	
Adjustable Power Factor	0.8 Leading~0.8 Lagging	
THDI	<3%	
AC Grid Connection Type	L1/L2/N/PE	

Output Data (Backup)

Max. Continuous Power	5000W
Peak Power	6000W
Nominal AC Voltage	240V
Max. Output Current	25A
THD	5%

Efficiency

Max. Efficiency	98.4%	98.5%
CEC Efficiency @240V AC / @208V	97.5% / 97.0%	98.0% / 97.5%

Protection Devices

DC Reverse-polarity Protection	Yes
DC Disconnect Switch	Yes
DC Surge Protection	Type II
Insulation Resistance Monitoring	Yes
AC Surge Protection	Type III
AC Short-circuit Protection	Yes
Ground Fault Monitoring	Yes
Grid Monitoring	Yes
Anti-Islanding Protection	Yes
Residual-current Monitoring Unit	Yes
AFCI Protection	Yes
PVRSS Rapid Shutdown	TS4-A-F, TS4-A-O
Module-level Monitoring	TS4-A-O

General Data

Operating Temperature Range	-25°C ~ +60°C (-13°F ~ +140°F) de-rating above 45°C/113°F
Altitude	3000m (9843ft)
Internal Consumption at Night	<1W (for PV Inverter) / <5W (for storage inverter)
Cooling	Natural Convection
Electronics Protection Degree	NEMA 4X (IP65)
Relative Humidity	0~95%

Interfaces

RS485	Yes
WiFi/4G Communication	WiFi Standard / 4G Optional
Warranty	152 months
Revenue Grade Meter	ANSI C12.20 (meets 0.5% accuracy)

Certifications

UL 1699B, UL 1741, UL 1741 SA, CSA C22.2, IEEE 1547, CA Rule 21, Rule 14 (HECO compliant), FCC part 15 class B, PVRSS



Additional resources





Efficiency Curves

TSI-7.6K-US (208V)

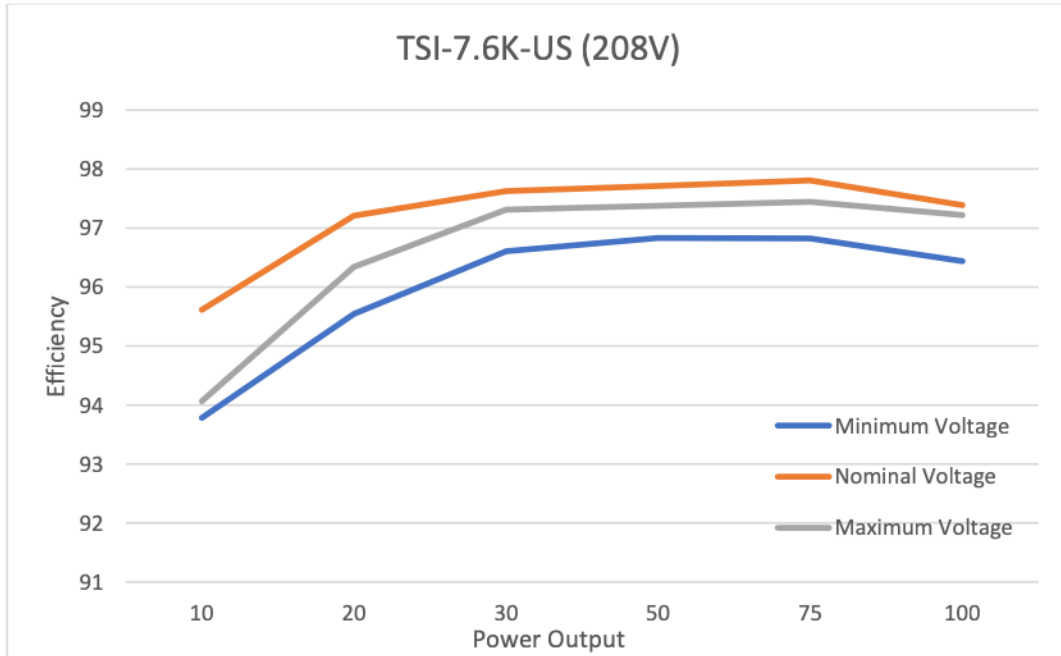

TSI-7.6K-US (240V)

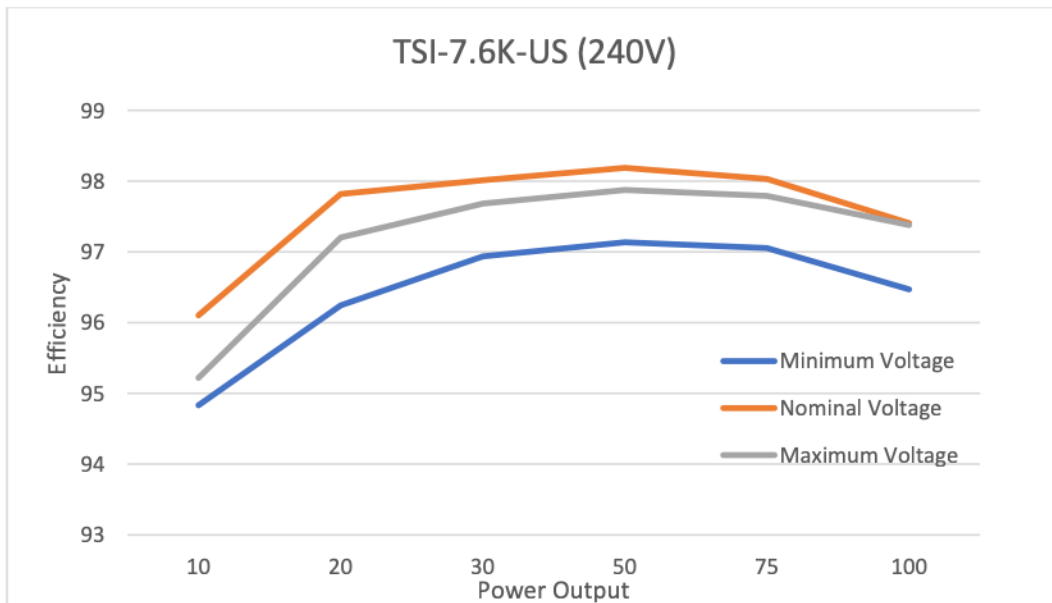

TSI-11.4K-US (208V)

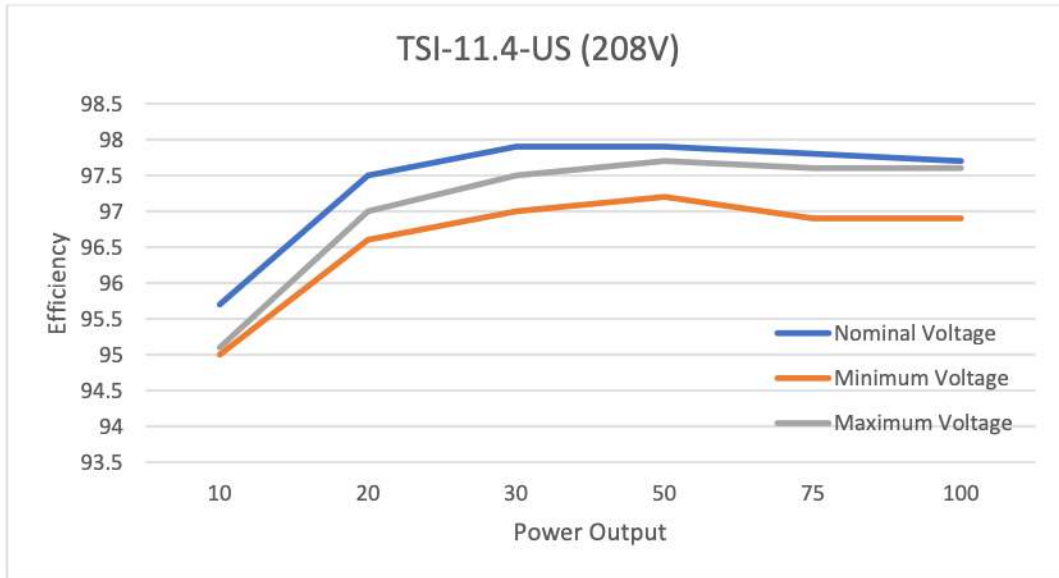

TSI-11.4K-US (240V)

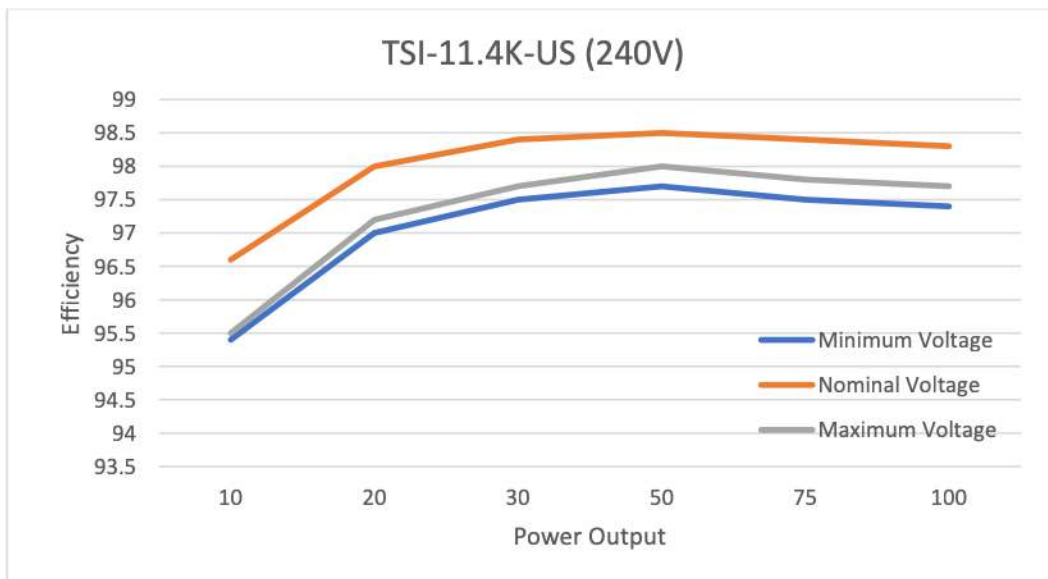



Ambient Temperature

The optimal operating temperature range of the EI Inverter is -13°F to 140°F (-25°C to 60°C). The inverter can operate at full power and full current up to 113°F (45°C), above which the inverter may operate with reduced output power to prevent damage.

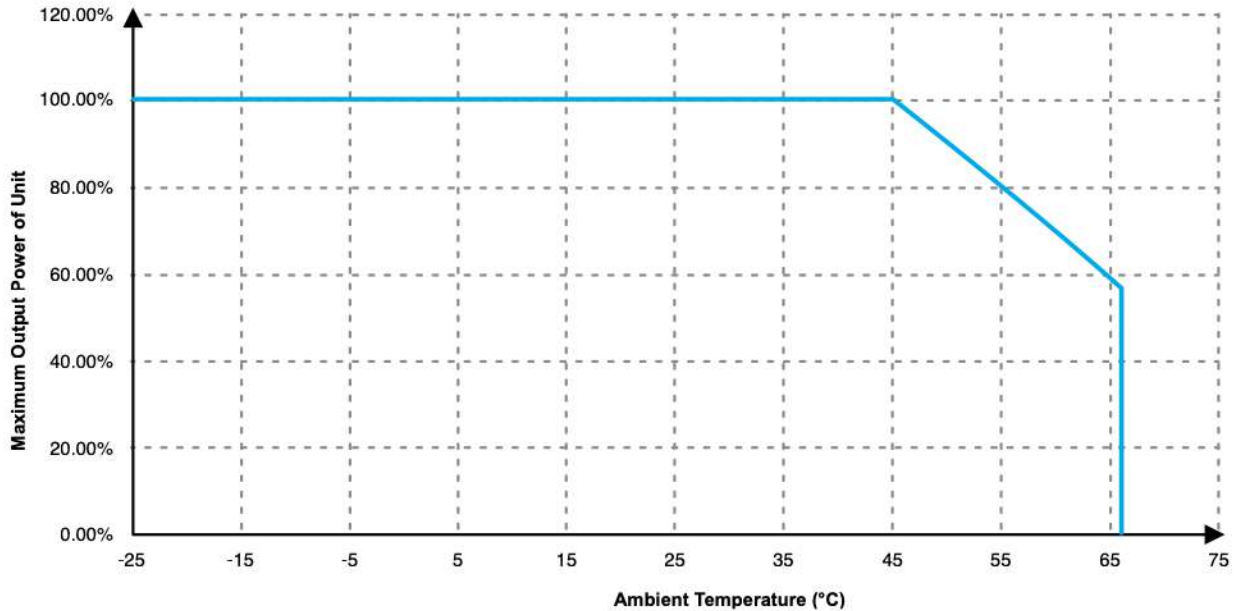

The inverter must be installed in a well-ventilated, cool, dry location. Due to tolerance of the internal thermal sensors and different efficiencies under varying PV voltages, this derating curve may not accurately reflect all situations.

Inverter data tolerance

Table 17 Inverter data tolerances

Parameter	Units	Default Measurement Tolerance
Voltage	Volts (V)	±1% rated V
Current	Amps (A)	±1% rated A
Power	Watts (W)	±1% rated P
Reactive Power	Volt-Amps (VA)	±1% rated VA
Power Factor	Decimal (0-1)	±0.01
Frequency	Hertz (Hz)	±0.05
Response time	Seconds (s)	1

Time accuracy	Total time	0.1%
---------------	------------	------

Annex

Rule 21 Parameter Settings

The EI Inverter includes a preset grid code for California Rule 21 (R21) settings. The following section describes the default settings required for Rule 21 compliance.

R21 parameter settings

Voltage ride-through

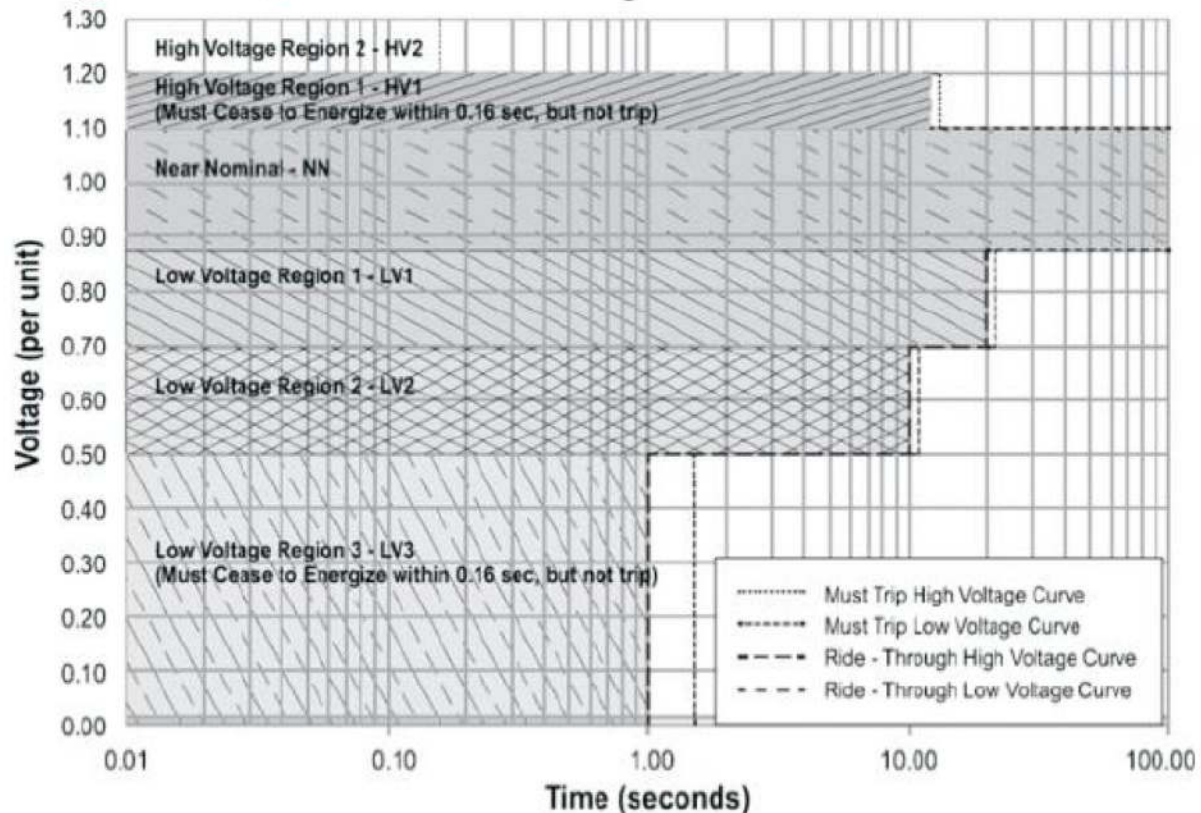

	Voltage (% of nominal)	Trip time	Mode
High voltage 2	$V \geq 120$	160ms	N/A
High voltage 1	$110 < V < 120$	13s	Momentary cessation
Near nominal	$88 \leq V \leq 110$	N/A	Continuous operation
Low voltage 1	$70 \leq V < 88$	21s	Mandatory operation
Low voltage 2	$50 \leq V < 70$	11s	Mandatory operation
Low voltage 3	$V < 50$	1.5s	Momentary cessation



Voltage ride-through

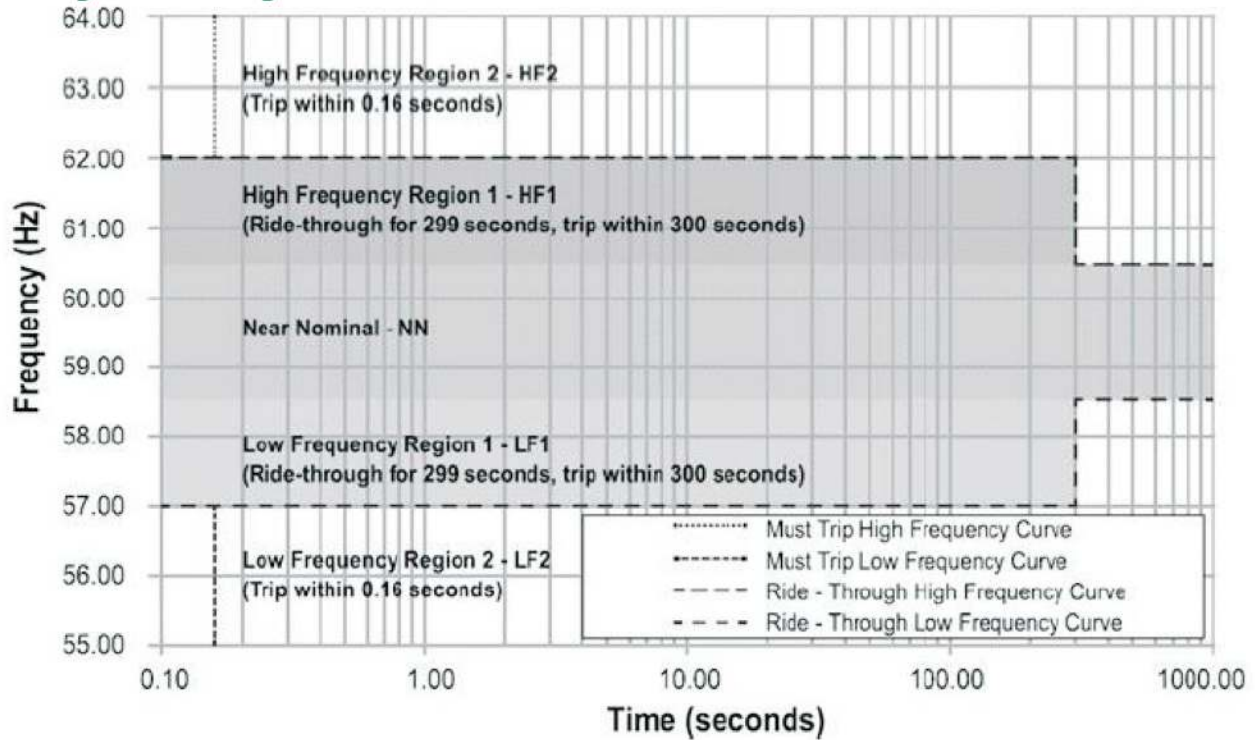

	R21 setting (Hz)	Adjustable Max/Min	Trip time	Mode
High frequency 2	62.0	64/62	160ms	N/A
High frequency 1	60.5	62/60.1	300s	Mandatory operation
Low frequency 1	58.5	59.9/57	300s	Mandatory operation
Low frequency 2	57	57/53	160ms	N/A

Normal and soft start ramp rates

Ramp rate is the rate at which the inverter increases its energy production. Normal ramp rate (RR) is the ability to increase output during normal operation. Soft start (SS) is the increase in production when the inverter reconnects to the grid after the grid has lost power. The maximum output current per second is adjustable for both RR and SS, per the chart below.

Power output increase rate	Range of adjustability	
	Minimum	Maximum
RR	1% I_{NOM}/S	100% I_{NOM}/S
SS		

Fixed power factor

Power factor	Range of adjustability		Default setting
	Minimum	Maximum	
Inductive	0.85	1	1
Capacitive			

Dynamic Volt/VAR

The EI Inverter can provide dynamic reactive power compensation per the table and graph below.

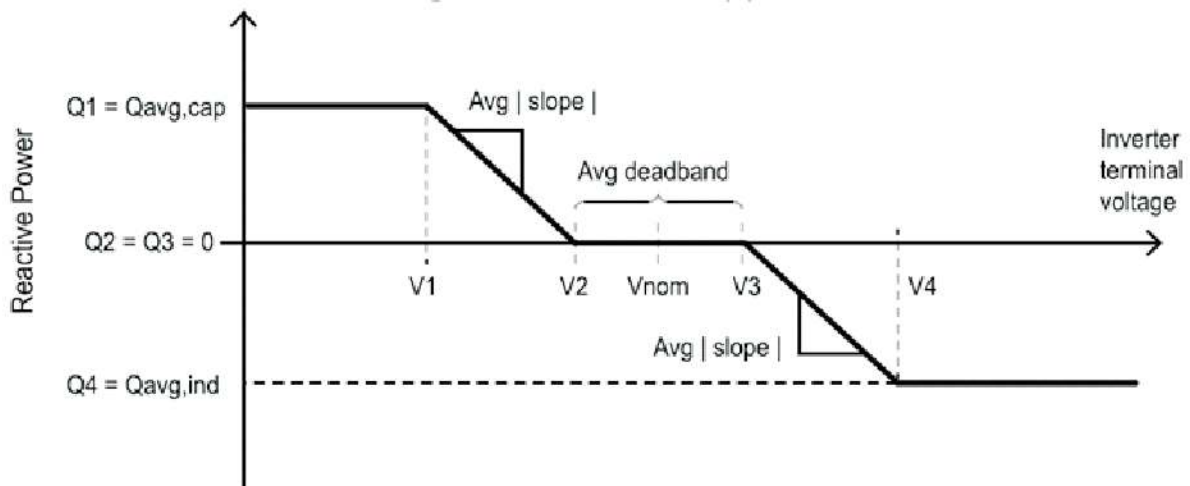

Volt-VAR parameter	Default value	Range of adjustability	
		Minimum	Maximum
V2	$0.92V_{NOM}$	$0.90V_{NOM}$	$1.05V_{NOM}$
Q2	0	0	60% of nameplate apparent power
V3	$1.08V_{NOM}$	$0.95V_{NOM}$	$1.10V_{NOM}$
Q3	0	0	60% of nameplate apparent power
V1	$0.90V_{NOM}$	$0.80V_{NOM}$	$1.03V_{NOM}$
Q1	48.4% of nameplate apparent power	0	60% of nameplate apparent power
V4	$1.10V_{NOM}$	$0.97V_{NOM}$	$1.18V_{NOM}$
Q4	48.4% of nameplate apparent power	0	60% of nameplate apparent power

Frequency-Watt (FW)

The EI Inverter can reduce the real power production as a function of system frequency as detailed below.

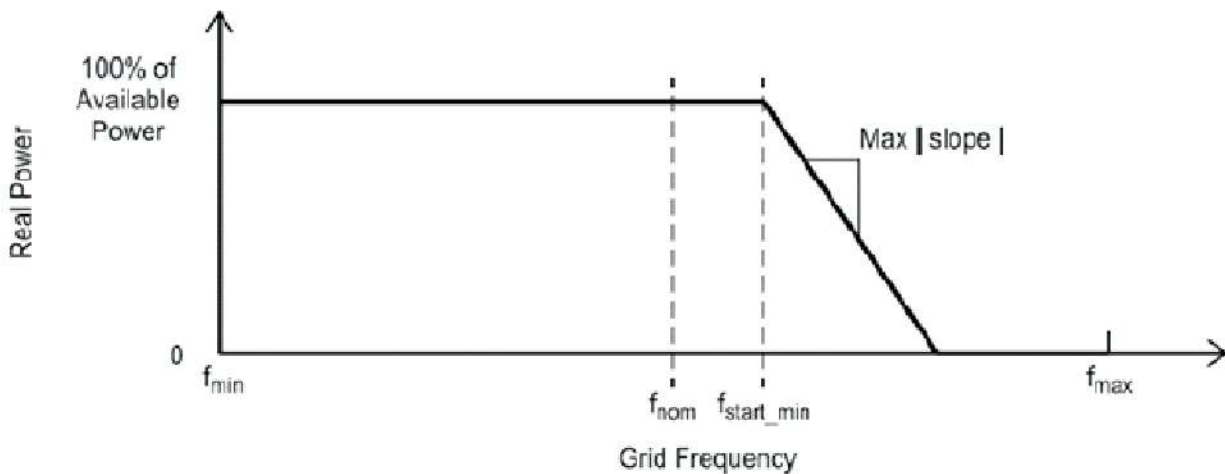

Parameter	Range of adjustability	Default setting
Overfrequency	60.017 – 61Hz	60.036Hz
Kof ($[(P_n/(60 \cdot Kof\%)]/Hz$)	2-7	5
Response time	50ms – 3s	60ms

Voltage-Watt (VW)

The EI Inverter can reduce the real power production as a function of measured voltage, as detailed below.

Volt-Watt parameter	Default value	Adjustable range	
		Minimum	Maximum
V1	1.06 V_{NOM}	1.03 V_{NOM}	1.10 V_{NOM}
P1	Pre-disturbance	N/A	N/A
V2	1.1 V_{NOM}	1.04 V_{NOM}	1.10 V_{NOM}
P2	P_{MIN}	P_{MIN}	P_{RATED}
Delay time	3s	0.5s	60s